

## Design of a Multi-Storied RC Building

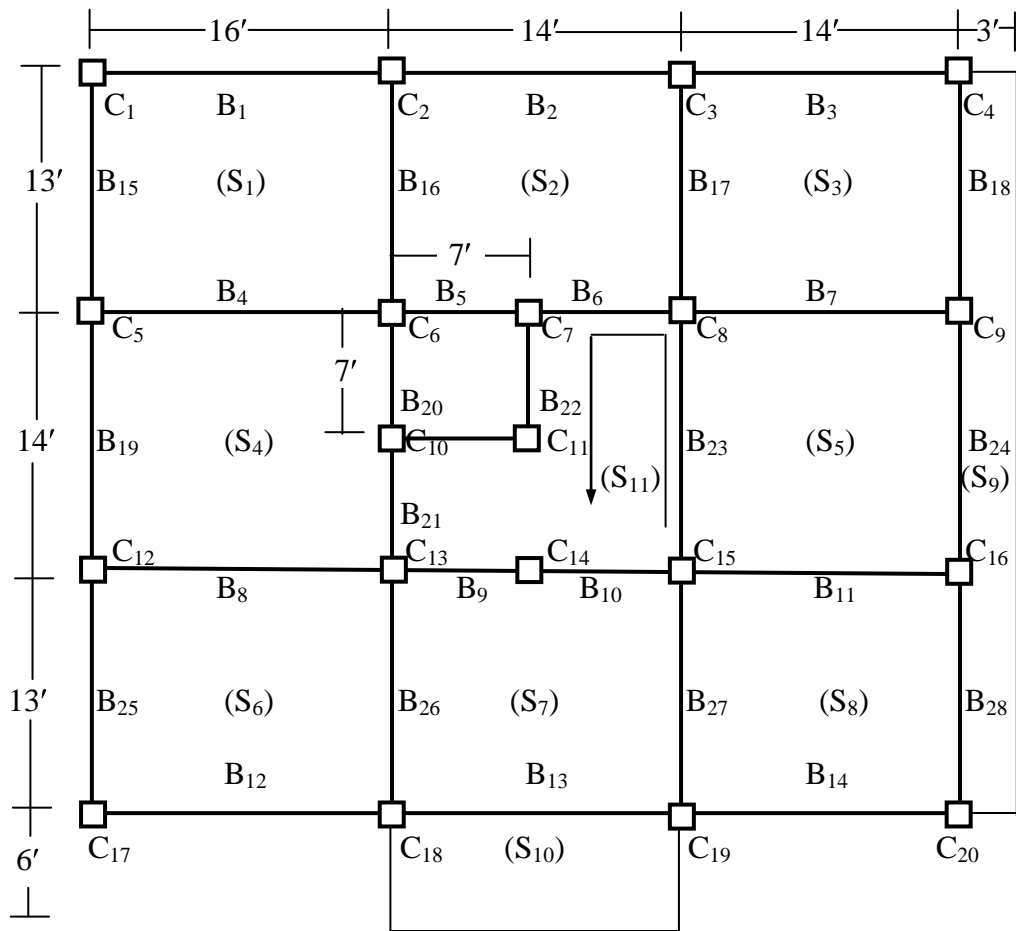

**Building Plan**

Building Height = 4@10' = 40'

Loads: LL = 40 psf, FF = 20 psf, RW = 20 psf

Seismic Coefficients: Z = 0.15, I = 1.0, S = 1.0, R = 5.0

Material Properties:  $f'_c = 3$  ksi,  $f_s = 20$  ksi, Allowable Bearing Capacity of soil = 2 ksf

## 1. Design of Slabs

Largest Slab is  $S_4$ , with clear area ( $13' \times 15'$ ).

$\therefore$  Assumed slab thickness,  $t = (13' + 15') \times 2 / 180 = 3.73''$ ; i.e.,  $4'' \Rightarrow d = 3''$  (or  $2.5''$  for  $M_{\min}$ )

$\therefore$  Self Wt. = 50 psf  $\Rightarrow$  DL = 50+20+20 = 90 psf = 0.09 ksf

LL = 40 psf = 0.04 ksf  $\Rightarrow$  Total Wt./slab area = 0.09 + 0.04 = 0.13 ksf

For design,  $n = 9$ ,  $k = 9 / (9 + 20 / 1.35) = 0.378$ ,  $j = 1 - k / 3 = 0.874$

$$R = \frac{1}{2} \times 1.35 \times 0.378 \times 0.874 = 0.223 \text{ ksi}$$

$$A_s = M / f_j d = M \times 12 / (20 \times 0.874 \times 3) = M / 4.37 \text{ (or } M / 3.64 \text{ for } M_{\min})$$

$$A_{s(\text{Temp})} = 0.0025 \text{ bt} = 0.0025 \times 12 \times 4 = 0.12 \text{ in}^2 /'$$

### Slab ( $S_1$ ):

Slab size ( $12' \times 15'$ ),  $m = 12 / 15 = 0.80$ , Support condition Case 4.

$$M_A^+ = (0.039 \times 0.09 + 0.048 \times 0.04) \times (12)^2 = 0.782 \text{ k}' \Rightarrow A_{s(A)}^+ = 0.782 / 4.37 = 0.18 \text{ in}^2 /'$$

$$M_B^+ = (0.016 \times 0.09 + 0.020 \times 0.04) \times (15)^2 = 0.504 \text{ k}' \Rightarrow A_{s(B)}^+ = 0.504 / 3.64 = 0.14 \text{ in}^2 /'$$

$$M_A^- = (0.071 \times 0.13) \times (12)^2 = 1.329 \text{ k}' \Rightarrow A_{s(A)}^- = 1.329 / 4.37 = 0.30 \text{ in}^2 /'$$

$$M_B^- = (0.029 \times 0.13) \times (15)^2 = 0.848 \text{ k}' \Rightarrow A_{s(B)}^- = 0.848 / 4.37 = 0.19 \text{ in}^2 /'$$

Also,  $d_{\text{req}} = \sqrt{(M_{\max} / R)} = \sqrt{(1.329 / 0.223)} = 2.44''$ , which is  $< 3''$ , OK.

### Slab ( $S_2$ ):

Slab size ( $12' \times 13'$ ),  $m = 12 / 13 = 0.92$ , Support condition Case 3.

$$M_A^+ = (0.023 \times 0.09 + 0.033 \times 0.04) \times (12)^2 = 0.488 \text{ k}' \Rightarrow A_{s(A)}^+ = 0.488 / 3.64 = 0.13 \text{ in}^2 /'$$

$$M_B^+ = (0.025 \times 0.09 + 0.028 \times 0.04) \times (13)^2 = 0.570 \text{ k}' \Rightarrow A_{s(B)}^+ = 0.570 / 4.37 = 0.13 \text{ in}^2 /'$$

$$M_A^- = 0 \Rightarrow A_{s(A)}^- = 0$$

$$M_B^- = (0.071 \times 0.13) \times (13)^2 = 1.560 \text{ k}' \Rightarrow A_{s(B)}^- = 1.560 / 4.37 = 0.36 \text{ in}^2 /'$$

Also,  $d_{\text{req}} = \sqrt{(M_{\max} / R)} = \sqrt{(1.560 / 0.223)} = 2.65''$ , which is  $< 3''$ , OK.

### Slab ( $S_3$ ):

Slab size ( $12' \times 13'$ ),  $m = 12 / 13 = 0.92$ , Support condition Case 4.

$$M_A^+ = (0.032 \times 0.09 + 0.037 \times 0.04) \times (12)^2 = 0.628 \text{ k}' \Rightarrow A_{s(A)}^+ = 0.628 / 4.37 = 0.14 \text{ in}^2 /'$$

$$M_B^+ = (0.023 \times 0.09 + 0.028 \times 0.04) \times (13)^2 = 0.539 \text{ k}' \Rightarrow A_{s(B)}^+ = 0.539 / 3.64 = 0.15 \text{ in}^2 /'$$

$$M_A^- = (0.058 \times 0.13) \times (12)^2 = 1.086 \text{ k}' \Rightarrow A_{s(A)}^- = 1.086 / 4.37 = 0.25 \text{ in}^2 /'$$

$$M_B^- = (0.042 \times 0.13) \times (13)^2 = 0.923 \text{ k}' \Rightarrow A_{s(B)}^- = 0.923 / 4.37 = 0.21 \text{ in}^2 /'$$

Also,  $d_{\text{req}} = \sqrt{(M_{\max} / R)} = \sqrt{(1.086 / 0.223)} = 2.21''$ , which is  $< 3''$ , OK.

#### Slab (S<sub>4</sub>):

Slab size (13'×15'),  $m = 13/15 = 0.87$ , Support condition between Case 5 and Case 9.

$$M_A^+ = (0.029 \times 0.09 + 0.038 \times 0.04) \times (13)^2 = 0.698 \text{ k}' \Rightarrow A_{s(A)}^+ = 0.698/4.37 = 0.16 \text{ in}^2/'$$

$$M_B^+ = (0.013 \times 0.09 + 0.020 \times 0.04) \times (15)^2 = 0.443 \text{ k}' \Rightarrow A_{s(B)}^+ = 0.443/3.64 = 0.12 \text{ in}^2/'$$

$$M_A^- = (0.075 \times 0.13) \times (13)^2 = 1.648 \text{ k}' \Rightarrow A_{s(A)}^- = 1.648/4.37 = 0.38 \text{ in}^2/'$$

$$M_B^- = (0.011 \times 0.13) \times (15)^2 = 0.322 \text{ k}' \Rightarrow A_{s(B)}^- = 0.322/4.37 = 0.07 \text{ in}^2/'$$

Also,  $d_{req} = \sqrt{(M_{max}/R)} = \sqrt{(1.648/0.223)} = 2.72''$ , which is  $< 3''$ , OK.

#### Slab (S<sub>5</sub>):

Slab size (13'×13'),  $m = 13/13 = 1.00$ , Support condition between Case 5 and Case 9.

$$M_A^+ = (0.025 \times 0.09 + 0.031 \times 0.04) \times (13)^2 = 0.590 \text{ k}' \Rightarrow A_{s(A)}^+ = 0.590/4.37 = 0.13 \text{ in}^2/'$$

$$M_B^+ = (0.019 \times 0.09 + 0.028 \times 0.04) \times (13)^2 = 0.478 \text{ k}' \Rightarrow A_{s(B)}^+ = 0.478/3.64 = 0.13 \text{ in}^2/'$$

$$M_A^- = (0.068 \times 0.13) \times (13)^2 = 1.494 \text{ k}' \Rightarrow A_{s(A)}^- = 1.494/4.37 = 0.34 \text{ in}^2/'$$

$$M_B^- = (0.016 \times 0.13) \times (13)^2 = 0.352 \text{ k}' \Rightarrow A_{s(B)}^- = 0.352/4.37 = 0.08 \text{ in}^2/'$$

Also,  $d_{req} = \sqrt{(M_{max}/R)} = \sqrt{(1.494/0.223)} = 2.59''$ , which is  $< 3''$ , OK.

#### Slab (S<sub>6</sub>):

Slab size (12'×15'),  $m = 12/15 = 0.80$ , Support condition Case 4.  $\therefore$  Same design as S<sub>1</sub>.

#### Slab (S<sub>7</sub>):

Slab size (12'×13'),  $m = 12/13 = 0.92$ , Support condition Case 8.

$$M_A^+ = (0.024 \times 0.09 + 0.033 \times 0.04) \times (12)^2 = 0.501 \text{ k}' \Rightarrow A_{s(A)}^+ = 0.501/4.37 = 0.11 \text{ in}^2/'$$

$$M_B^+ = (0.020 \times 0.09 + 0.025 \times 0.04) \times (13)^2 = 0.473 \text{ k}' \Rightarrow A_{s(B)}^+ = 0.473/3.64 = 0.13 \text{ in}^2/'$$

$$M_A^- = (0.041 \times 0.13) \times (12)^2 = 0.767 \text{ k}' \Rightarrow A_{s(A)}^- = 0.767/4.37 = 0.18 \text{ in}^2/'$$

$$M_B^- = (0.054 \times 0.13) \times (13)^2 = 1.186 \text{ k}' \Rightarrow A_{s(B)}^- = 1.186/4.37 = 0.27 \text{ in}^2/'$$

Also,  $d_{req} = \sqrt{(M_{max}/R)} = \sqrt{(1.186/0.223)} = 2.31''$ , which is  $< 3''$ , OK.

#### Slab (S<sub>8</sub>):

Slab size (12'×13'),  $m = 12/13 = 0.92$ , Support condition Case 4.  $\therefore$  Same design as S<sub>3</sub>.

#### Slab (S<sub>9</sub>):

One-way cantilever slab with clear span = 2.5'

$\therefore$  Required thickness,  $t = (L/10) \times (0.4 + f_y/100) = (2.5 \times 12/10) \times (0.4 + 40/100) = 2.4'' < 4''$ , OK

$\therefore w = w_{DL} + w_{FF} + w_{LL} = 50 + 20 + 40 = 110.00 \text{ psf} = 0.110 \text{ ksf}$

$\therefore M^- = 0.11 \times (2.5)^2 / 2 = 0.344 \text{ k}' \Rightarrow A_s^- = 0.344/4.37 = 0.08 \text{ in}^2/'$

Slab (S<sub>10</sub>):

One-way cantilever slab with clear span = 5.5'

$$\therefore \text{Required thickness, } t = (5.5 \times 12 / 10) \times (0.4 + 40 / 100) = 5.28'' \Rightarrow 5.5''$$

$$\therefore w = w_{DL} + w_{FF} + w_{LL} = 68.75 + 20 + 20 = 108.75 \text{ psf} = 0.109 \text{ ksf}$$

$$\therefore M^- = 0.109 \times (5.5)^2 / 2 = 1.644 \text{ k}' \Rightarrow A_s^- = 1.644 \times 12 / (20 \times 0.874 \times (5.5 - 1)) = 0.25 \text{ in}^2'$$

Slab (S<sub>11</sub>):

One-way simply supported slab with c/c span = 14' [two 3' landings and one 8' flight]

Assumed LL on stairs = 100 psf

$$\therefore \text{Required thickness, } t = (14 \times 12 / 20) \times (0.4 + 40 / 100) = 6.72'' \Rightarrow 7''; \text{ Self weight} = 87.5 \text{ psf.}$$

$$\therefore \text{Weight on landing, } w_1 = w_{DL} + w_{FF} + w_{LL} = 87.5 + 20 + 100 = 207.5 \text{ psf} = 0.208 \text{ ksf}$$

$$\text{Additional weight on flights due to 6'' high stairs} = \frac{1}{2} \times (6 / 12) \times 150 \text{ psf} = 0.037 \text{ ksf}$$

$$\therefore \text{Weight on flight, } w_2 = 0.208 + 0.037 = 0.245 \text{ ksf}$$

$$\therefore M_{\max} \cong 0.245 \times (14)^2 / 8 = 6.003 \text{ k}'$$

$$\therefore d_{\text{req}} = \sqrt{(M_{\max} / R)} = \sqrt{(6.003 / 0.223)} = 5.19'', \text{ which is } < (7 - 1) = 6'', \text{ OK.}$$

$$\Rightarrow A_s^+ = 6.003 \times 12 / (20 \times 0.874 \times (7 - 1)) = 0.69 \text{ in}^2'; \text{ i.e., } \#5 @ 5'' \text{ c/c}$$

$$A_{s(\text{Temp})} = 0.0025 \text{ bt} = 0.0025 \times 12 \times 7 = 0.21 \text{ in}^2'; \text{ i.e., } \#3 @ 6'' \text{ c/c}$$

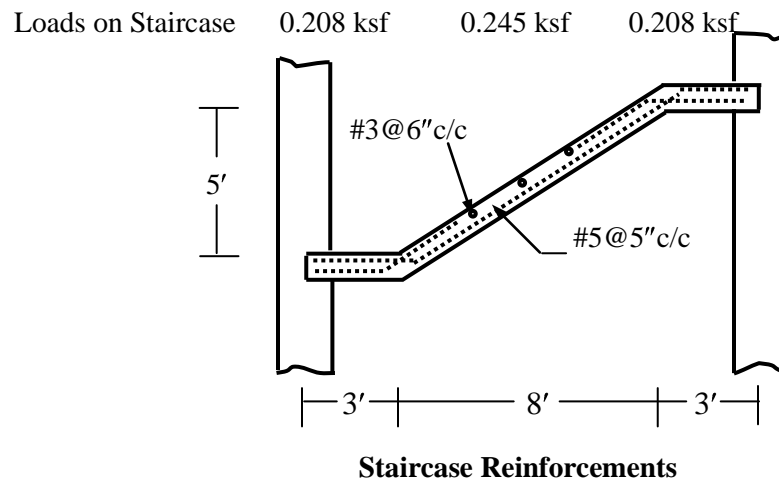

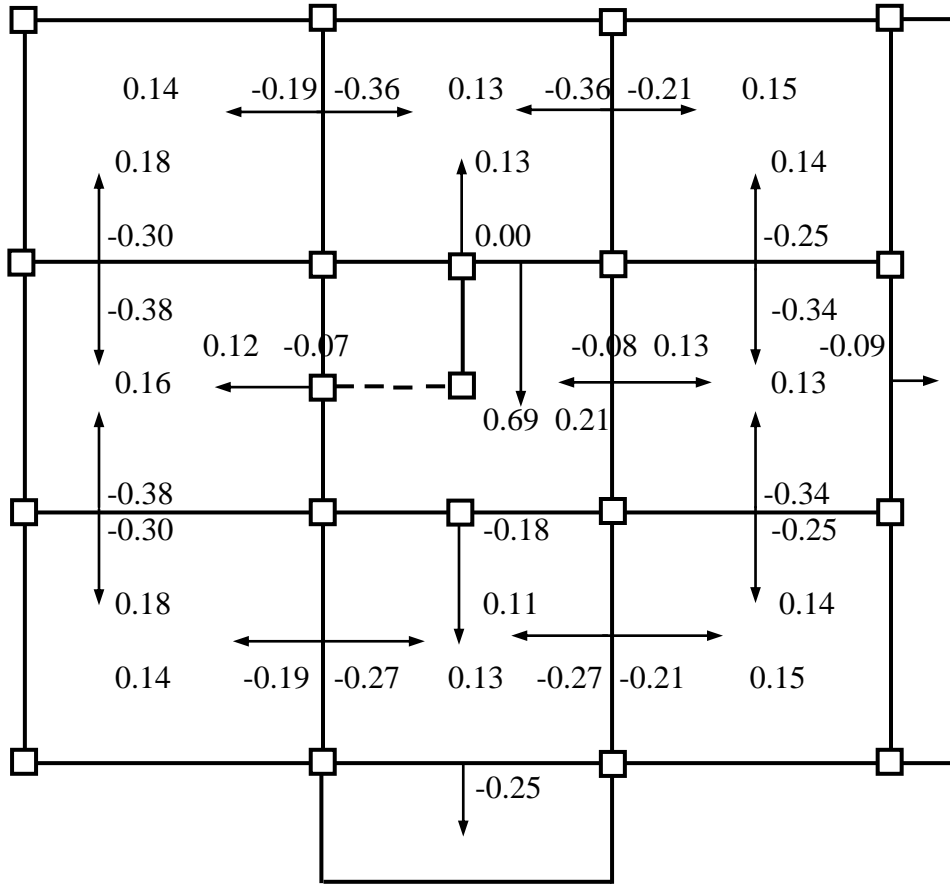

**Required Slab Reinforcement (in<sup>2</sup>/ft) from Flexural Design**  
 [Note:  $A_{s(Temp)} = 0.12 \text{ in}^2/\text{ft}$  and  $S_{max} = 2t$ , must be considered in all cases]

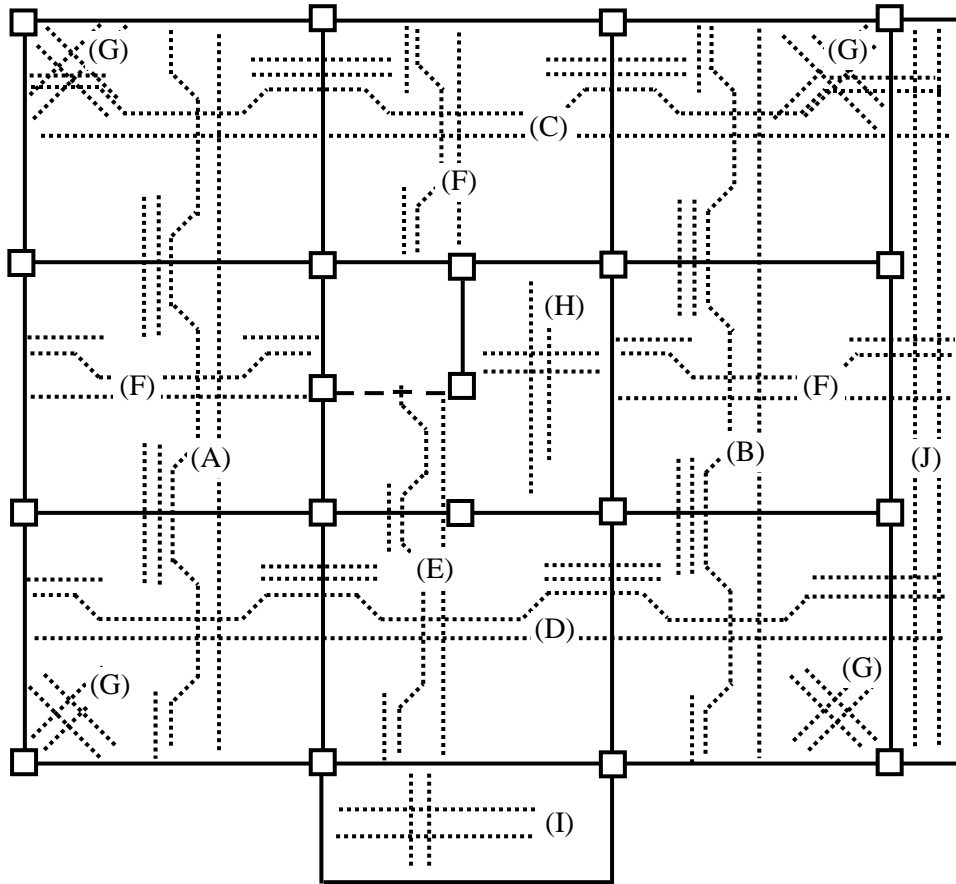

### Slab Reinforcements

- (A): #3@7" c/c, alt. ckd. with (1#3, 1#4) extra top
- (B): #3@8" c/c, alt. ckd. with (2#4) extra top
- (C): #3@8" c/c, alt. ckd. with (2#4) extra top
- (D): #3@8" c/c, alt. ckd. with (1#3, 1#4) extra top
- (E): #3@8" c/c, alt. ckd. with (1#4) extra top
- (F): #3@8" c/c, alt. ckd. with (1#3) extra top
- (G): Corner Reinforcement – #3@7" c/c at top and bottom, parallel to Slab diagonals
- (H): Staircase Reinforcement – #5@5" c/c Main (bottom), #3@6" c/c Temperature Rod
- (I): S<sub>10</sub> Reinforcement – #3@5" c/c at Main (top), #3@10" c/c Temperature Rod
- (J): S<sub>9</sub> Reinforcement – Temperature Rod #3@8" c/c both ways

## 2. Vertical Load Analysis of Beams and Columns

Beams are assumed to be 12"×12" below the slab.

∴ Self-weight of Beams =  $(12" \times 12") \times 150 / 144 = 150 \text{ lb}' = 0.15 \text{ k}'$

Weight of 5" Partition Walls (PW) =  $(5" / 12) \times 9' \times 120 = 450 \text{ lb}' = 0.45 \text{ k}'$

∴ Weight of 10" Exterior Walls (EW) =  $0.90 \text{ k}'$

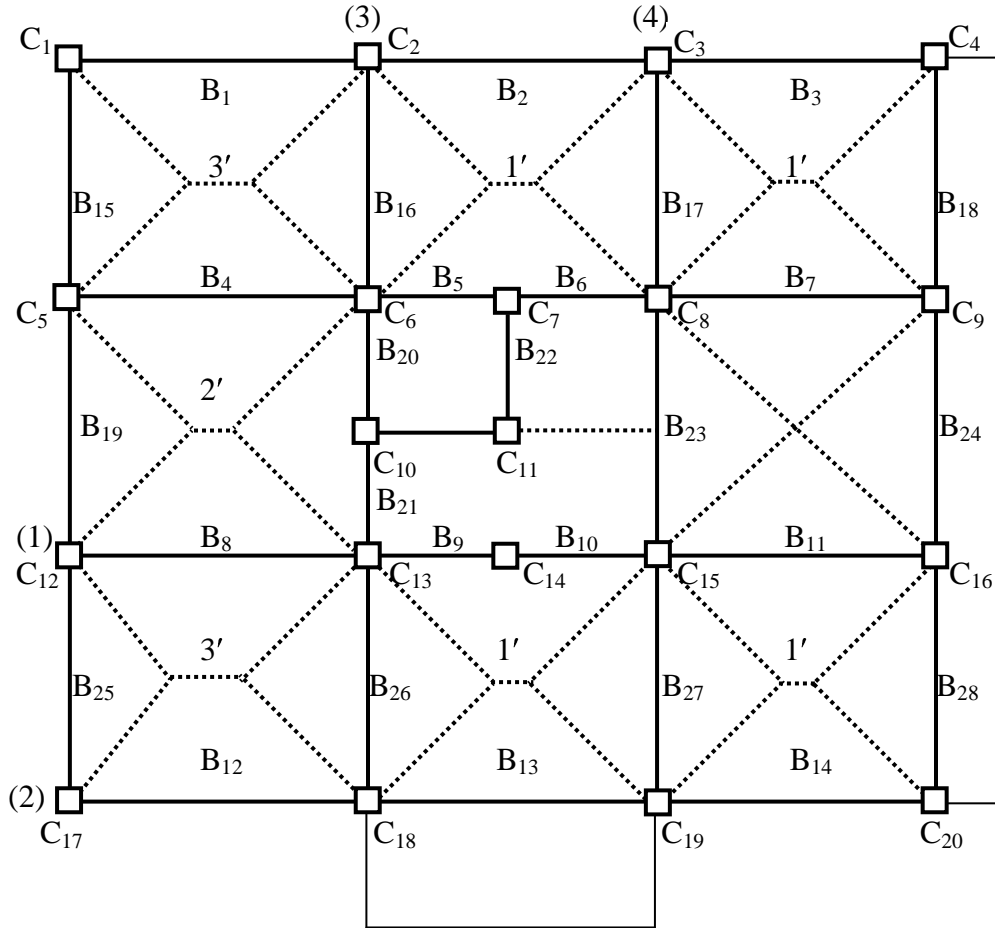

**Load Distribution from Slab to Beam**

Frame (1) [B<sub>8-9-10-11</sub>]:

Slab-load on B<sub>8</sub> =  $[13/2 \times (16+3)/2 + 14/2 \times (16+2)/2] \times 0.13 = 16.22^k$

∴ Equivalent UDL (+ Self Wt. and PW)  $\cong 16.22/16 + 0.15 + 0.45 = 1.61 \text{ k}'$

Slab-load on B<sub>9-10</sub>  $\cong 13/2 \times (14+1)/2 \times 0.13 + (14 \times 14 - 7 \times 7)/2 \times (0.208 + 0.245)/2$   
 $= 6.34 + 16.65 = 22.99^k$

∴ Equivalent UDL (+ Self Wt. and PW)  $\cong 22.99/14 + 0.15 + 0.45 = 2.24 \text{ k}'$

Load from Slabs to B<sub>11</sub> =  $[13/2 \times (14+1)/2 + 14/2 \times (14)/2] \times 0.13 = 12.71^k$

∴ Equivalent UDL (+ Self Wt. and PW)  $\cong 12.71/14 + 0.15 + 0.45 = 1.51 \text{ k}'$

[One cannot use the ACI Coefficients here due to large differences in adjacent Spans]

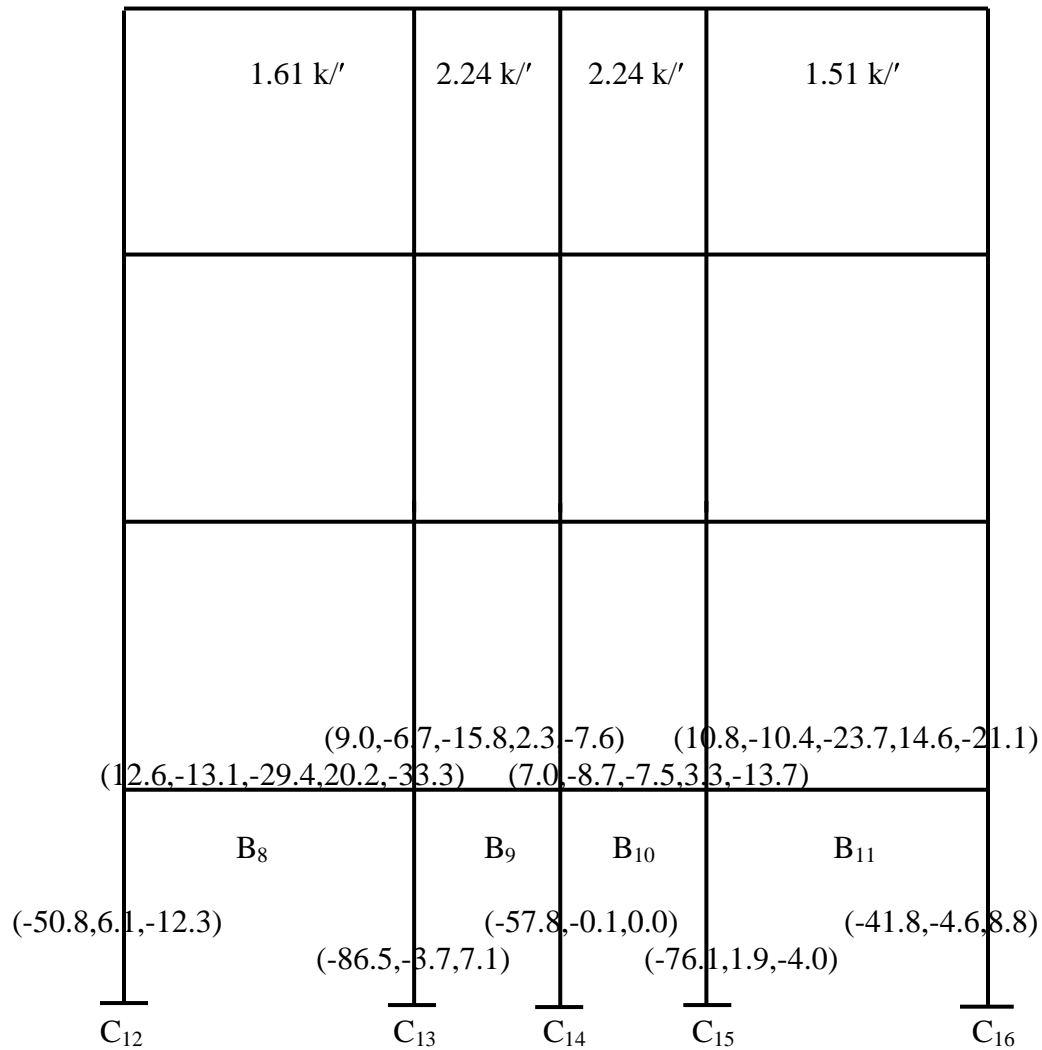

**Beam (SF<sub>1</sub>, SF<sub>2</sub> (k), BM<sub>1</sub>, BM<sub>0</sub>, BM<sub>2</sub> (k')) and Column (AF (k), BM<sub>1</sub>, BM<sub>2</sub> (k')) in Frame (1) from Vertical Load Analysis**



Frame (2) [B<sub>12-13-14</sub>]:

Slab-load on B<sub>12</sub> =  $[13/2 \times (16+3)/2] \times 0.13 = 8.03^k$

∴ Equivalent UDL (+ Self Wt. and EW)  $\cong 8.03/16 + 0.15 + 0.90 = 1.55 \text{ k}'$

Slab-load on B<sub>13</sub> =  $[13/2 \times (14+1)/2] \times 0.13 = 6.34^k$

∴ Equivalent UDL (+ Self Wt. and EW)  $\cong 6.34/14 + 0.15 + 0.90 = 1.50 \text{ k}'$

Load from Slabs to B<sub>14</sub> =  $[13/2 \times (14+1)/2] \times 0.13 = 6.34^k$

∴ Equivalent UDL (+ Self Wt. and EW)  $\cong 6.34/14 + 0.15 + 0.90 = 1.50 \text{ k}'$

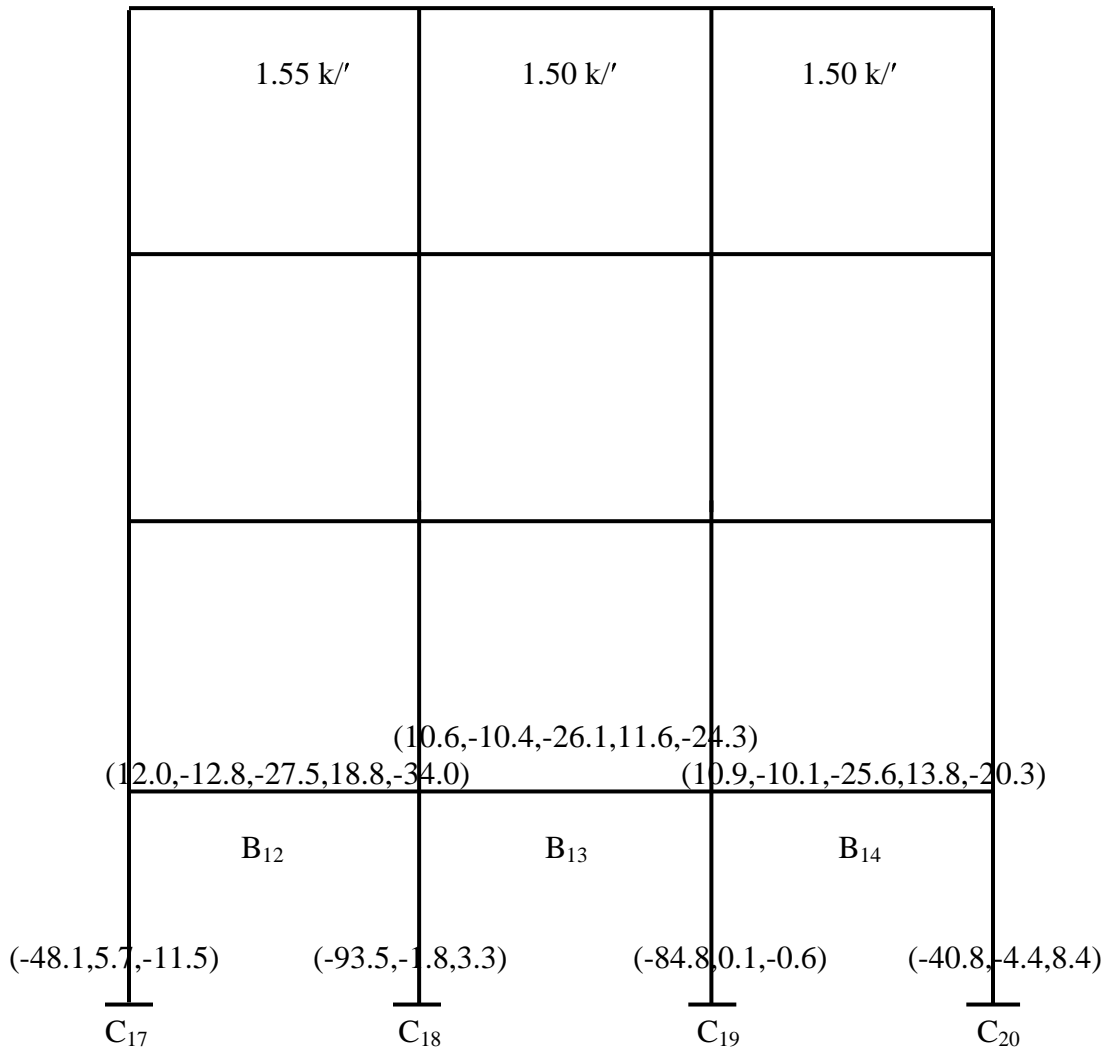

**Beam (SF<sub>1</sub>, SF<sub>2</sub> (k), BM<sub>1</sub>, BM<sub>0</sub>, BM<sub>2</sub> (k')) and Column (AF (k), BM<sub>1</sub>, BM<sub>2</sub> (k')) in Frame (2) from Vertical Load Analysis**

Frame (3) [B<sub>16-20-21-26</sub>]:

Slab-load on B<sub>16</sub> and B<sub>26</sub> =  $[13/2 \times (13)/2 + 13/2 \times (13)/2] \times 0.13 = 10.99^k$

∴ Equivalent UDL (+ Self Wt. and PW)  $\cong 10.99/13 + 0.15 + 0.45 = 1.45 \text{ k}'$

Slab-load on B<sub>20-21</sub>  $\cong [14/2 \times (14)/2] \times 0.13 = 6.37^k$

∴ Equivalent UDL (+ Self Wt. and PW)  $\cong 6.37/14 + 0.15 + 0.45 = 1.06 \text{ k}'$

[One cannot use ACI Coefficients here due to large differences in adjacent Spans]

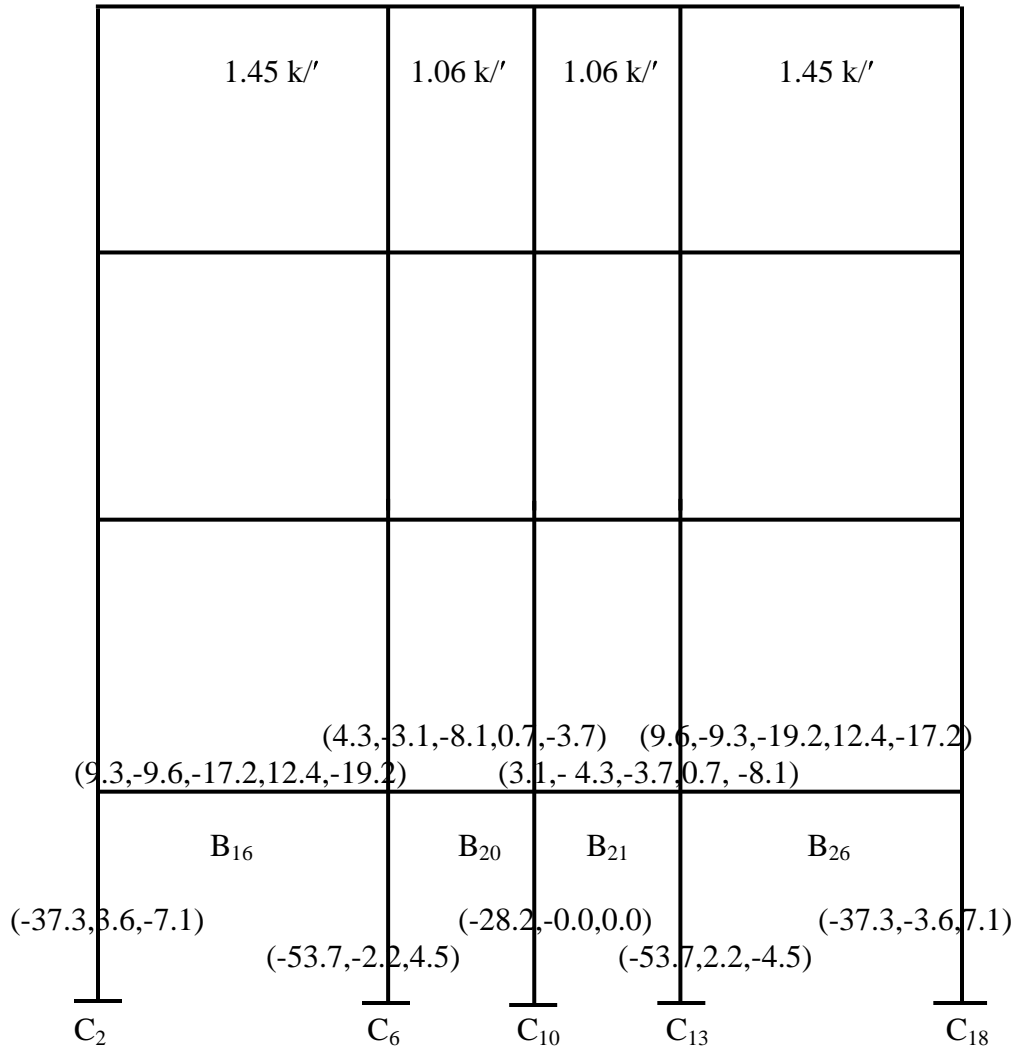

**Beam (SF<sub>1</sub>, SF<sub>2</sub> (k), BM<sub>1</sub>, BM<sub>0</sub>, BM<sub>2</sub> (k')) and Column (AF (k), BM<sub>1</sub>, BM<sub>2</sub> (k')) in Frame (3) from Vertical Load Analysis**

Frame (4) [B<sub>17-23-27</sub>]:

Slab-load on B<sub>17</sub> and B<sub>27</sub> =  $[13/2 \times (13)/2 + 13/2 \times (13)/2] \times 0.13 = 10.99^k$

∴ Equivalent UDL (+ Self Wt. and PW)  $\cong 10.99/13 + 0.15 + 0.45 = 1.45 \text{ k}'$

Slab-load on B<sub>23</sub> =  $[14/2 \times (14)/2] \times 0.13 = 6.37^k$

∴ Equivalent UDL (+ Self Wt., EW, S<sub>9</sub>)  $\cong 6.37/14 + 0.15 + 0.90 + 3 \times 0.13 = 1.90 \text{ k}'$

[Here, the EW is considered because the exterior beam B<sub>24</sub> is more critical. It has the same slab load as B<sub>23</sub> in addition to self-weight and EW]

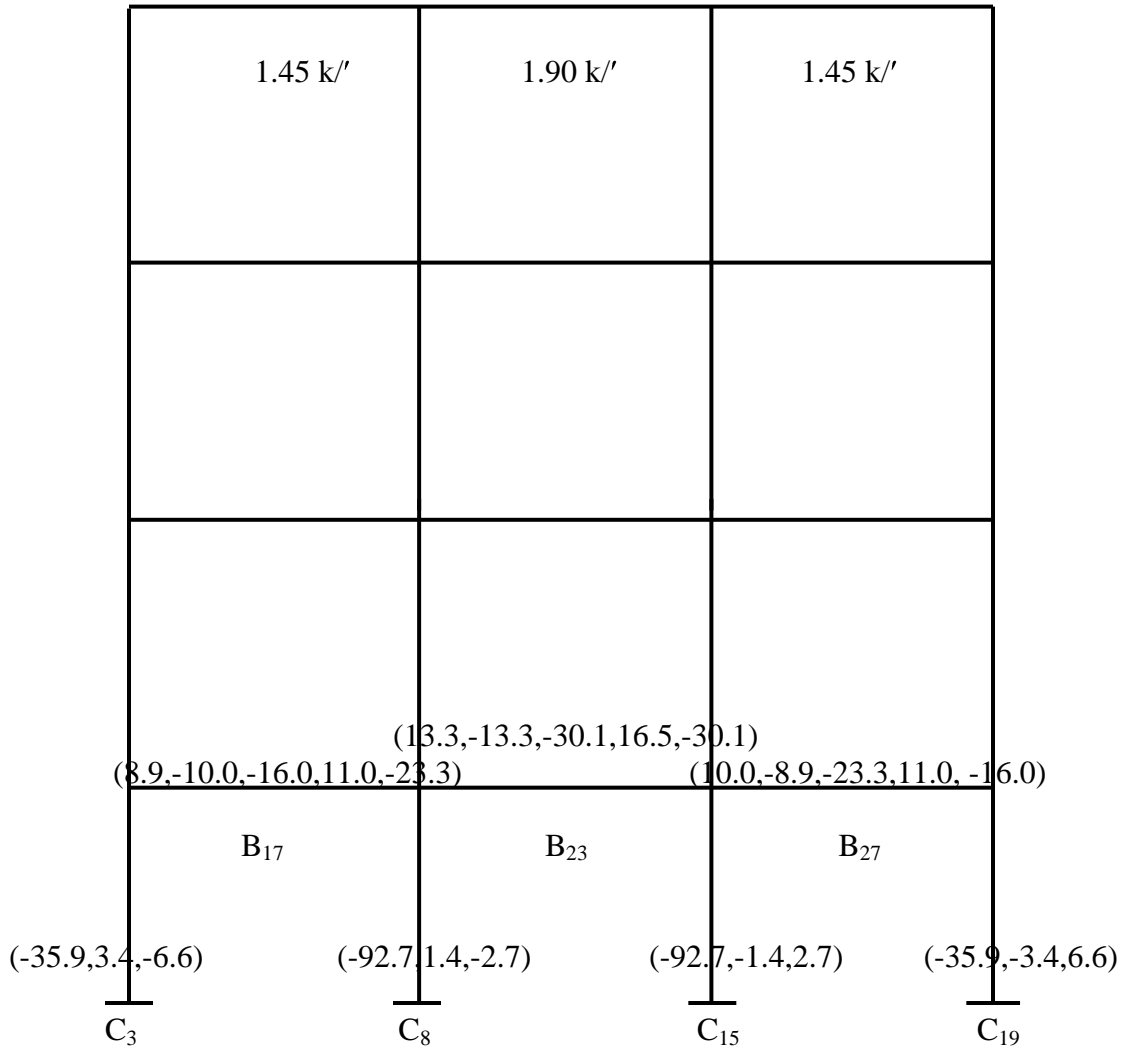

**Beam (SF<sub>1</sub>, SF<sub>2</sub> (k), BM<sub>1</sub>, BM<sub>0</sub>, BM<sub>2</sub> (k')) and Column (AF (k), BM<sub>1</sub>, BM<sub>2</sub> (k')) in Frame (4) from Vertical Load Analysis**

Frame [B<sub>4-5-6-7</sub>]:

Similar to Frame (1) [B<sub>8-9-10-11</sub>].

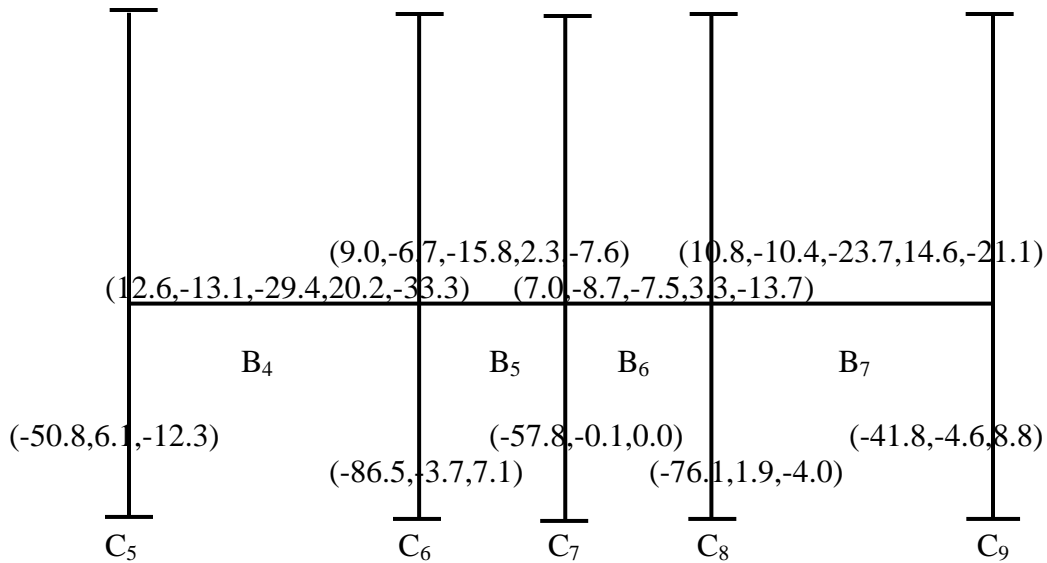

**Beam (SF<sub>1</sub>, SF<sub>2</sub> (k), BM<sub>1</sub>, BM<sub>0</sub>, BM<sub>2</sub> (k')) and Column (AF (k), BM<sub>1</sub>, BM<sub>2</sub> (k')) in Frame [B<sub>4-5-6-7</sub>] from Vertical Load Analysis**

Frame [B<sub>1-2-3</sub>]:

Similar to Frame (2) [B<sub>12-13-14</sub>].

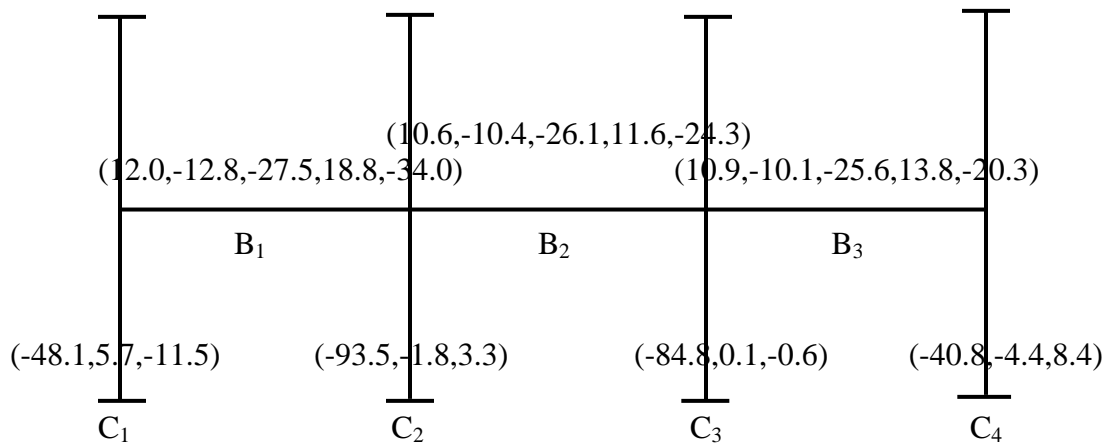

**Beam (SF<sub>1</sub>, SF<sub>2</sub> (k), BM<sub>1</sub>, BM<sub>0</sub>, BM<sub>2</sub> (k')) and Column (AF (k), BM<sub>1</sub>, BM<sub>2</sub> (k')) in Frame [B<sub>1-2-3</sub>] from Vertical Load Analysis**

Frame [B<sub>15-19-25</sub>]:

Similar to Frame (4) [B<sub>17-23-27</sub>].

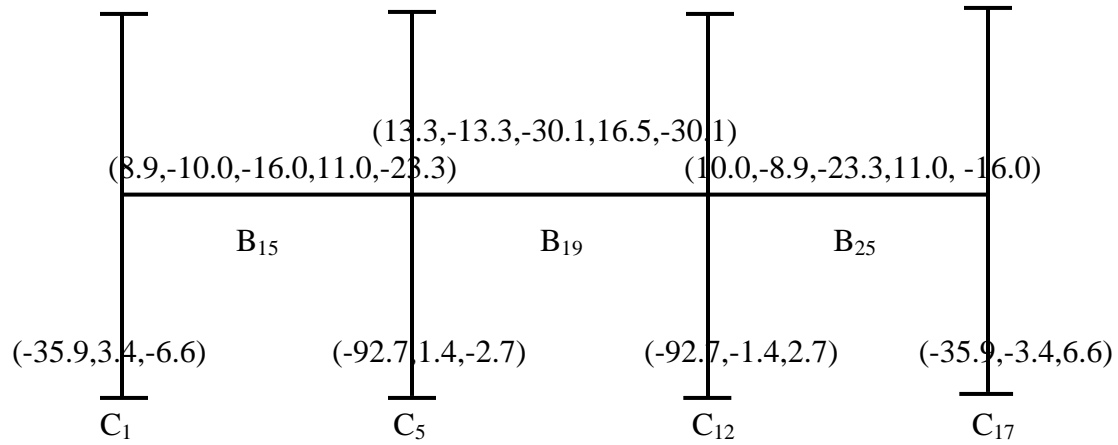

**Beam (SF<sub>1</sub>, SF<sub>2</sub> (k), BM<sub>1</sub>, BM<sub>0</sub>, BM<sub>2</sub> (k')) and Column (AF (k), BM<sub>1</sub>, BM<sub>2</sub> (k')) in Frame [B<sub>15-19-25</sub>] from Vertical Load Analysis**

Frame [B<sub>18-24-28</sub>]:

Similar to Frame (4) [B<sub>17-23-27</sub>].

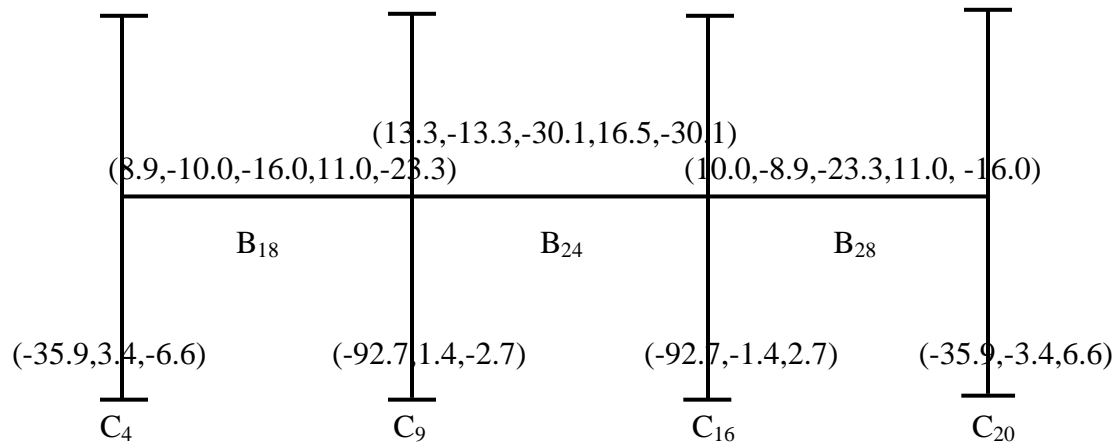

**Beam (SF<sub>1</sub>, SF<sub>2</sub> (k), BM<sub>1</sub>, BM<sub>0</sub>, BM<sub>2</sub> (k')) and Column (AF (k), BM<sub>1</sub>, BM<sub>2</sub> (k')) in Frame [B<sub>18-24-28</sub>] from Vertical Load Analysis**

### 3. Lateral Load Analysis of Beams and Columns

Seismic Coefficients:  $Z = 0.15$ ,  $I = 1.0$ ,  $S = 1.0$ ,  $R = 5.0$

For RCC structures,  $T = 0.073 \times (40/3.28)^{3/4} = 0.476$  sec, which is  $< 0.7$  sec  $\Rightarrow V_1 = 0$ .

$$C = 1.25 S/T^{2/3} = 2.05 \leq 2.75 \quad [h = 40' = \text{Building Height in ft}]$$

$\therefore$  Base Shear,  $V = (ZIC/R) W = 0.15 \times 1.0 \times 2.05 / 5.0 W = 0.0615 W$

$\therefore$  For equally loaded stories,  $F_i = (h_i / \sum h_i) V \Rightarrow F_1 = 0.1V$ ,  $F_2 = 0.2V$ ,  $F_3 = 0.3V$ ,  $F_4 = 0.4V$

Frame (1) [B<sub>8-9-10-11</sub>]:

$$W = 4 \times (1.61 \times 16 + 2.24 \times 7 + 2.24 \times 7 + 1.51 \times 14) = 313.04^k \Rightarrow V = 0.0615W = 19.25^k$$

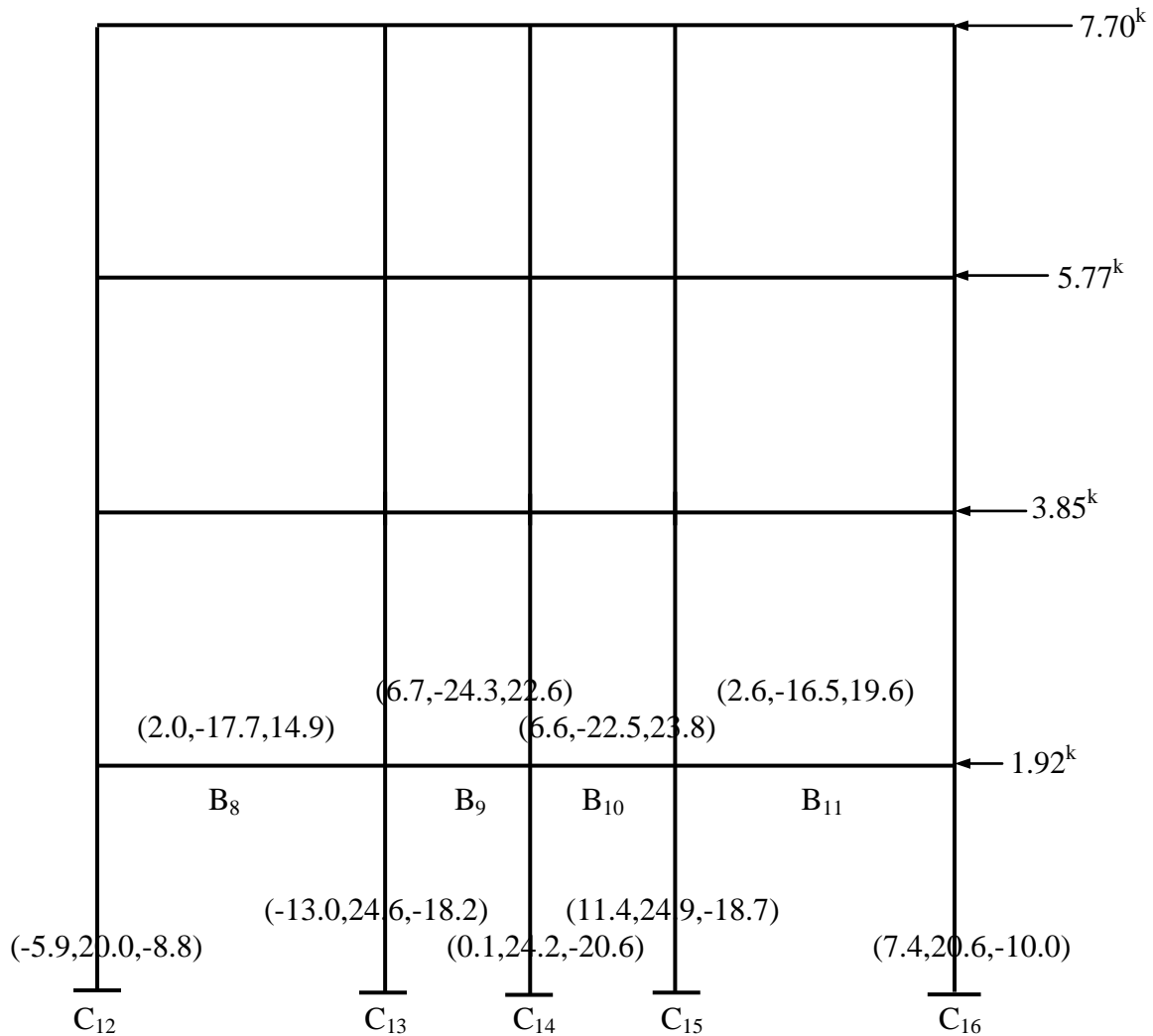

**Beam (SF(k), BM<sub>1</sub>, BM<sub>2</sub> (k')) and Column (AF (k), BM<sub>1</sub>, BM<sub>2</sub> (k')) in Frame (1) from Lateral Load Analysis**

Frame (2) [B<sub>12-13-14</sub>]:

$$W = 4 \times (1.55 \times 16 + 1.50 \times 14 + 1.50 \times 14) = 267.20^k \Rightarrow V = 0.0615W = 16.43^k$$

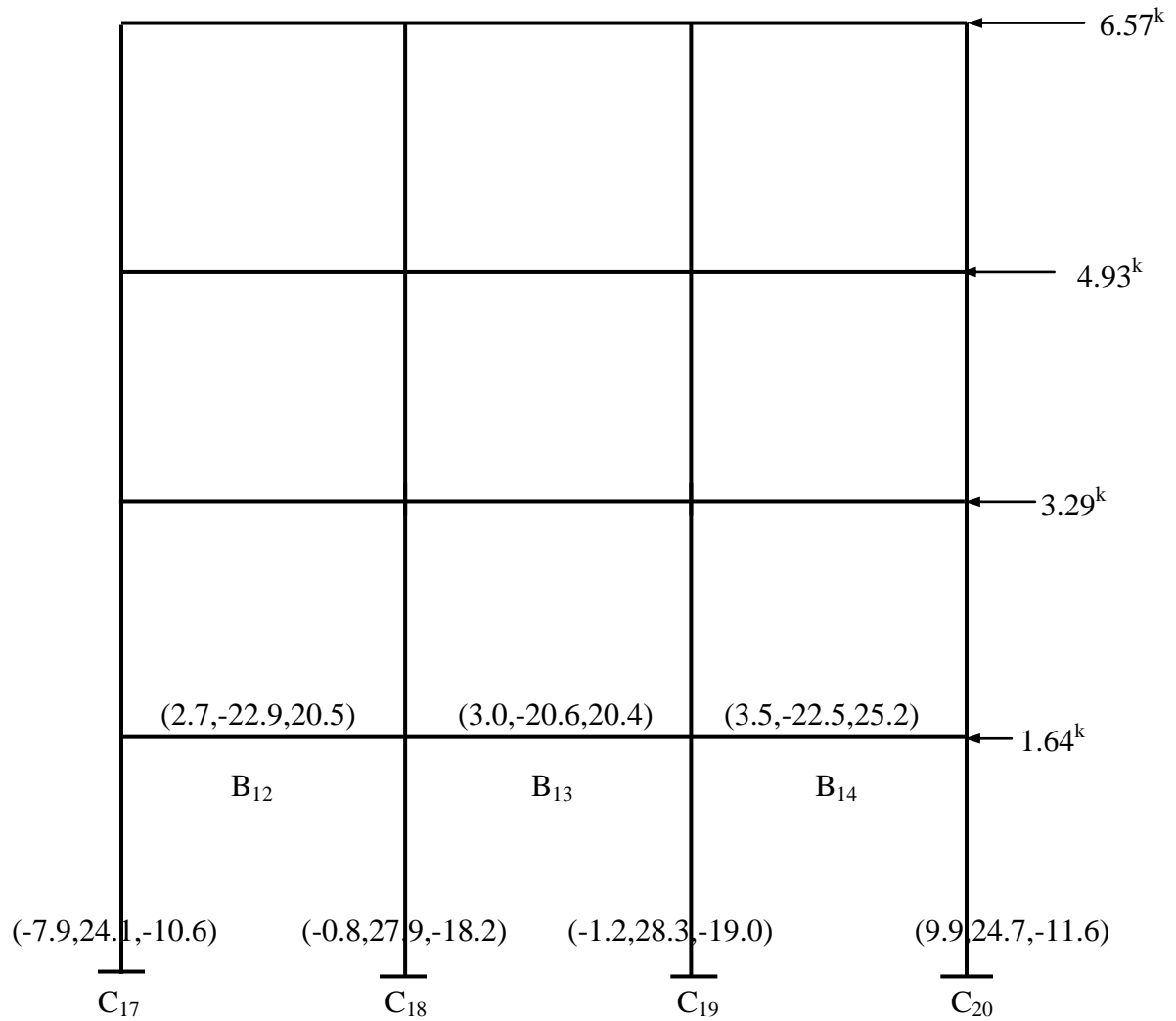

**Beam (SF(k), BM<sub>1</sub>, BM<sub>2</sub> (k')) and Column (AF (k), BM<sub>1</sub>, BM<sub>2</sub> (k')) in Frame (2) from Lateral Load Analysis**

Frame (3) [B<sub>16-20-21-26</sub>]:

$$W = 4 \times (1.45 \times 13 + 1.06 \times 7 + 1.06 \times 7 + 1.45 \times 13) = 210.16^k \Rightarrow V = 0.0615W = 12.92^k$$

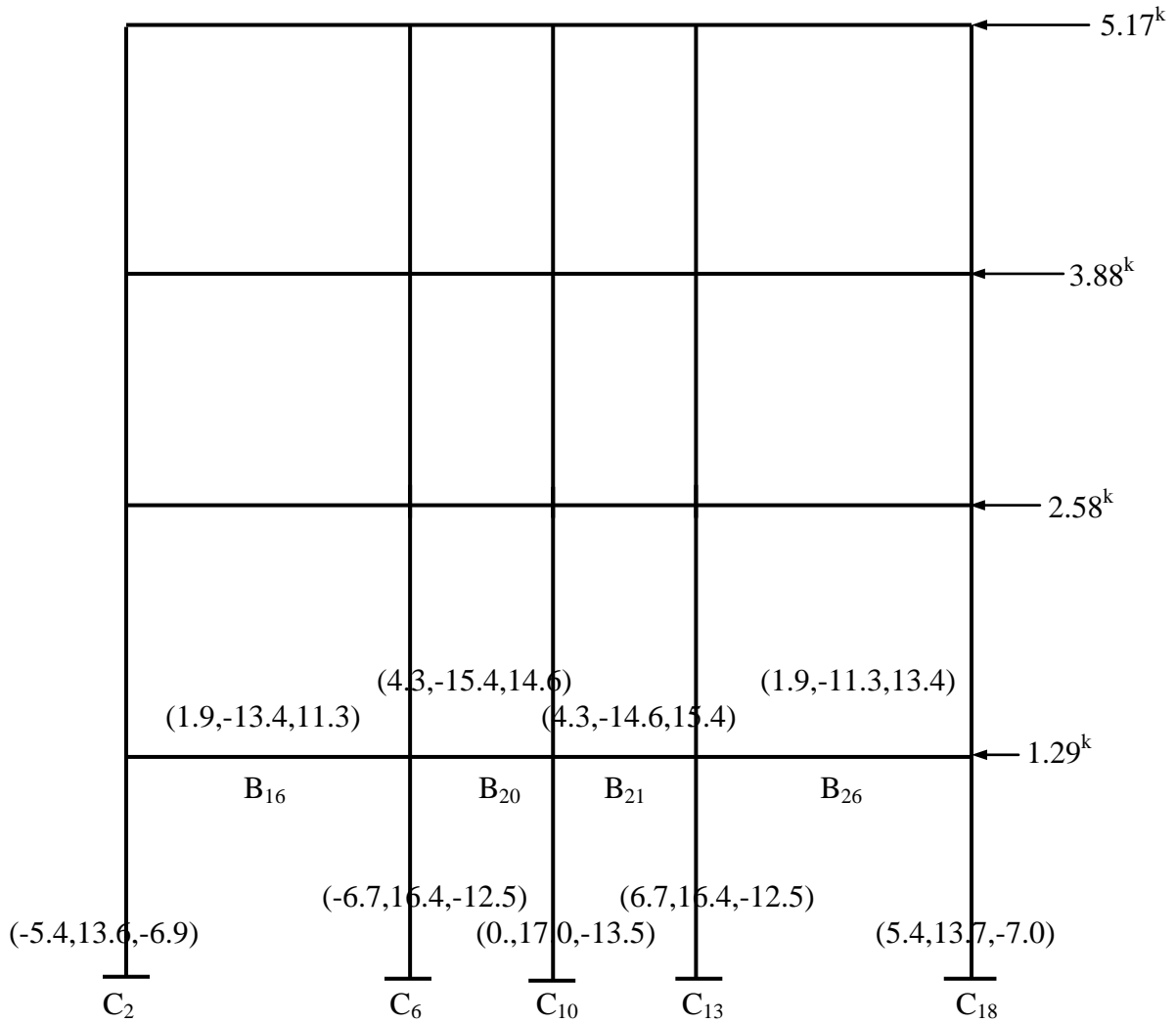

**Beam (SF(k), BM<sub>1</sub>, BM<sub>2</sub> (k')) and Column (AF (k), BM<sub>1</sub>, BM<sub>2</sub> (k')) in Frame (3) from Lateral Load Analysis**



Frame (4) [B<sub>17-23-27</sub>]:

$$W = 4 \times (1.45 \times 13 + 1.90 \times 14 + 1.45 \times 13) = 257.20^k \Rightarrow V = 0.0615W = 15.81^k$$

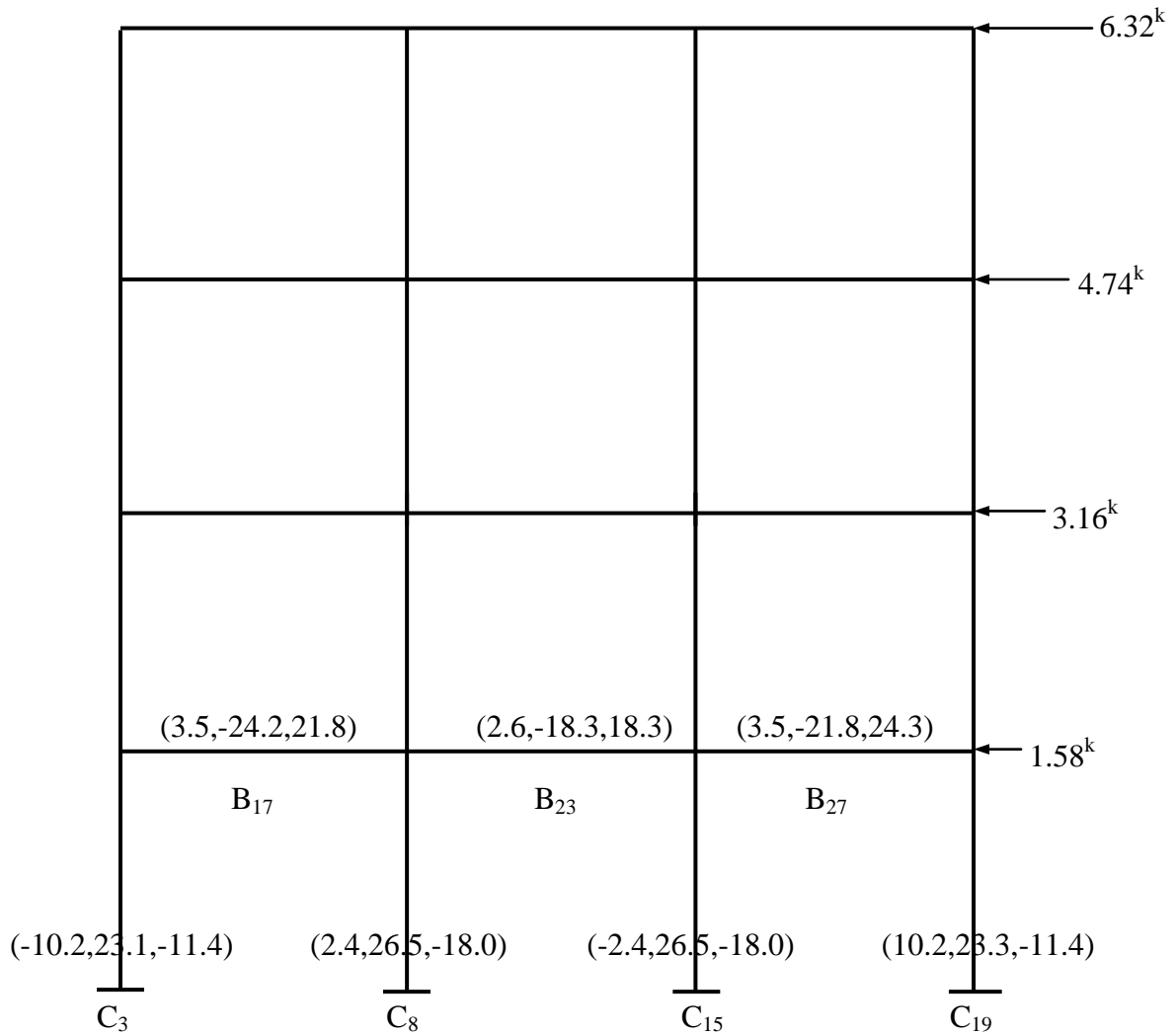

**Beam (SF(k), BM<sub>1</sub>, BM<sub>2</sub> (k')) and Column (AF (k), BM<sub>1</sub>, BM<sub>2</sub> (k')) in Frame (4) from Lateral Load Analysis**

Frame [B<sub>4-5-6-7</sub>]:

Similar to Frame (1) [B<sub>8-9-10-11</sub>].

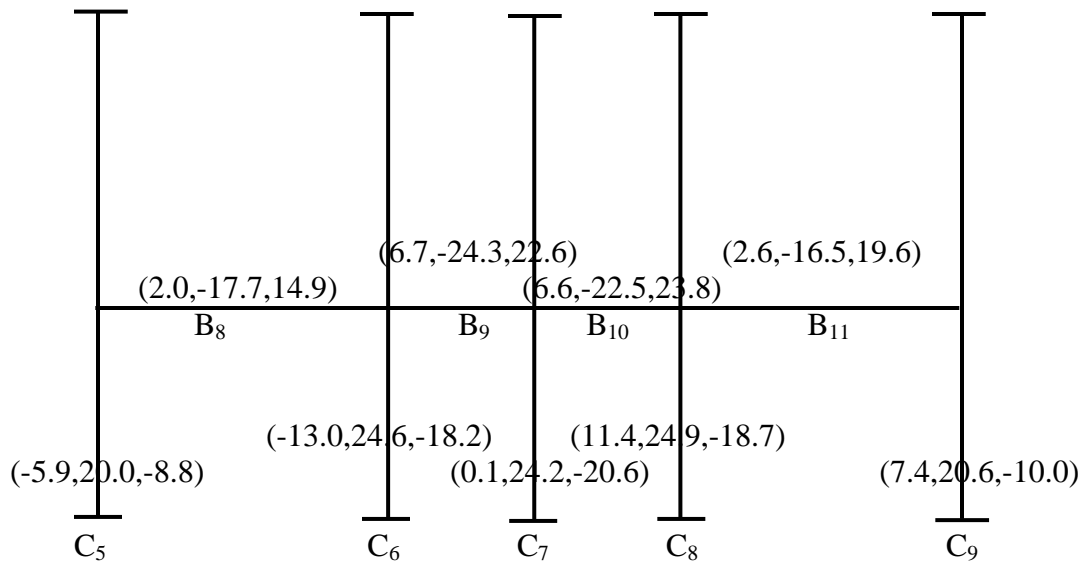

**Beam (SF (k), BM<sub>1</sub>, BM<sub>2</sub> (k')) and Column (AF (k), BM<sub>1</sub>, BM<sub>2</sub> (k')) in Frame [B<sub>4-5-6-7</sub>] from Lateral Load Analysis**

Frame [B<sub>1-2-3</sub>]:

Similar to Frame (2) [B<sub>12-13-14</sub>].

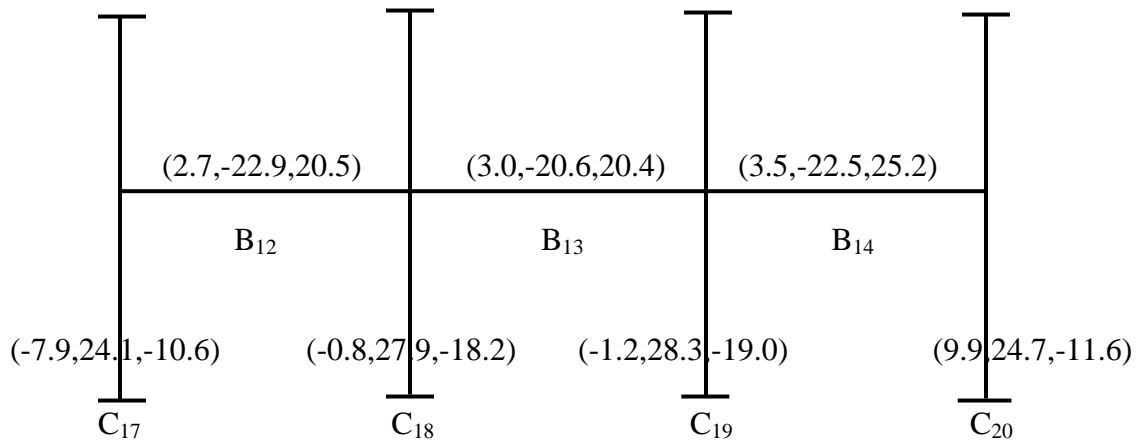

**Beam (SF (k), BM<sub>1</sub>, BM<sub>2</sub> (k')) and Column (AF (k), BM<sub>1</sub>, BM<sub>2</sub> (k')) in Frame [B<sub>1-2-3</sub>] from Lateral Load Analysis**

Frame [B<sub>15-19-25</sub>]:

Similar to Frame (4) [B<sub>17-23-27</sub>].

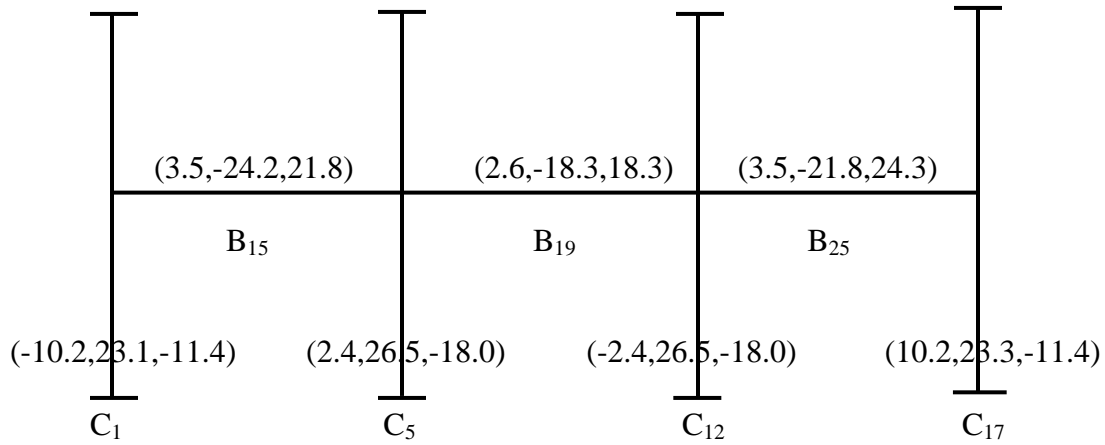

**Beam (SF (k), BM<sub>1</sub>, BM<sub>2</sub> (k')) and Column (AF (k), BM<sub>1</sub>, BM<sub>2</sub> (k')) in Frame [B<sub>15-19-25</sub>] from Lateral Load Analysis**

Frame [B<sub>18-24-28</sub>]:

Similar to Frame (4) [B<sub>17-23-27</sub>].

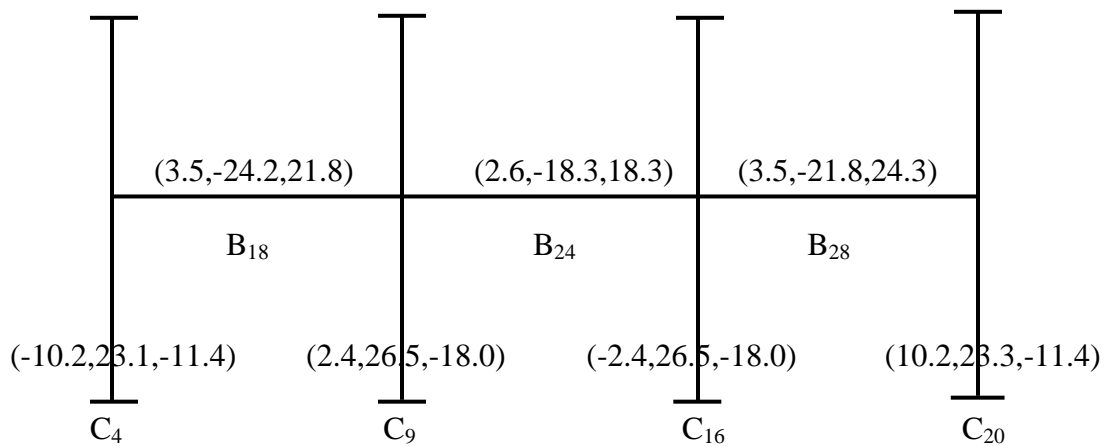

**Beam (SF (k), BM<sub>1</sub>, BM<sub>2</sub> (k')) and Column (AF (k), BM<sub>1</sub>, BM<sub>2</sub> (k')) in Frame [B<sub>18-24-28</sub>] from Lateral Load Analysis**

#### 4. Combination of Vertical and Lateral Loads

The Design Force (i.e., AF, SF or BM) will be the maximum between the following two combinations

(i) Vertical Force = DL+LL

(ii) Combined Vertical and Lateral Force = 0.75 (DL+LL+EQ); i.e., 0.75 times the combined force from Vertical and Lateral Load Analysis.

The design Shear Forces and Bending Moments for various beams are calculated below using the two options mentioned above.

##### 4.1 Load Combination for Beams

Frame (1) [B<sub>4-5-6-7</sub>] and [B<sub>8-9-10-11</sub>]:

Beams	SF <sub>1</sub> (V)	SF <sub>1</sub> (L)	SF <sub>1</sub> (D)	SF <sub>2</sub> (V)	SF <sub>2</sub> (L)	SF <sub>2</sub> (D)
B <sub>4</sub> , B <sub>8</sub>	12.6	±2.0	12.6	-13.1	±2.0	-13.1
B <sub>5</sub> , B <sub>9</sub>	9.0	±6.7	11.8	-6.7	±6.7	-10.1
B <sub>6</sub> , B <sub>10</sub>	7.0	±6.6	10.2	-8.7	±6.6	-11.5
B <sub>7</sub> , B <sub>11</sub>	10.8	±2.0	10.8	-10.4	±2.0	-10.4

Beams	BM <sub>1</sub> (V)	BM <sub>1</sub> (L)	BM <sub>1</sub> (D)	BM <sub>0</sub> (V=D)	BM <sub>2</sub> (V)	BM <sub>2</sub> (L)	BM <sub>2</sub> (D)
B <sub>4</sub> , B <sub>8</sub>	-29.4	±17.7	-35.3	20.2	-33.3	±14.9	-36.2
B <sub>5</sub> , B <sub>9</sub>	-15.8	±24.3	6.4, -30.1	2.3	-7.6	±22.6	11.3, -22.7
B <sub>6</sub> , B <sub>10</sub>	-7.5	±22.5	11.3, -22.5	3.3	-13.7	±23.8	7.6, -28.1
B <sub>7</sub> , B <sub>11</sub>	-23.7	±16.5	-30.2	14.6	-21.1	±19.6	-30.5

Frame (2) [B<sub>1-2-3</sub>] and [B<sub>12-13-14</sub>]:

Beams	SF <sub>1</sub> (V)	SF <sub>1</sub> (L)	SF <sub>1</sub> (D)	SF <sub>2</sub> (V)	SF <sub>2</sub> (L)	SF <sub>2</sub> (D)
B <sub>1</sub> , B <sub>12</sub>	12.0	±2.3	12.0	-12.8	±2.3	-12.8
B <sub>2</sub> , B <sub>13</sub>	10.6	±3.0	10.6	-10.4	±3.0	-10.4
B <sub>3</sub> , B <sub>14</sub>	10.9	±3.5	10.9	-10.1	±3.5	-10.2

Beams	BM <sub>1</sub> (V)	BM <sub>1</sub> (L)	BM <sub>1</sub> (D)	BM <sub>0</sub> (V=D)	BM <sub>2</sub> (V)	BM <sub>2</sub> (L)	BM <sub>2</sub> (D)
B <sub>1</sub> , B <sub>12</sub>	-27.5	±22.9	-37.8	18.8	-34.0	±20.5	-40.9
B <sub>2</sub> , B <sub>13</sub>	-26.1	±20.6	-35.0	11.6	-24.3	±20.4	-33.5
B <sub>3</sub> , B <sub>14</sub>	-25.6	±22.5	-36.1	13.8	-20.3	±25.2	-34.1

Frame (3) [B<sub>16-20-21-26</sub>]:

Beams	SF <sub>1</sub> (V)	SF <sub>1</sub> (L)	SF <sub>1</sub> (D)	SF <sub>2</sub> (V)	SF <sub>2</sub> (L)	SF <sub>2</sub> (D)
B <sub>16</sub>	9.3	±1.9	9.3	-9.6	±1.9	-9.6
B <sub>20</sub>	4.3	±4.3	6.5	-3.1	±4.3	-5.6
B <sub>21</sub>	3.1	±4.3	5.6	-4.3	±4.3	-6.5
B <sub>26</sub>	9.6	±1.9	9.6	-9.3	±1.9	-9.3

Beams	BM <sub>1</sub> (V)	BM <sub>1</sub> (L)	BM <sub>1</sub> (D)	BM <sub>0</sub> (V=D)	BM <sub>2</sub> (V)	BM <sub>2</sub> (L)	BM <sub>2</sub> (D)
B <sub>16</sub>	-20.5	±13.4	-23.0	12.4	-22.9	±11.3	-22.9
B <sub>20</sub>	-9.5	±15.4	5.5, -17.6	0.7	-4.2	±14.6	8.2, -13.7
B <sub>21</sub>	-4.2	±14.6	8.2, -13.7	0.7	-9.5	±15.4	5.5, -17.6
B <sub>26</sub>	-22.9	±11.3	-22.9	12.4	-20.5	±13.4	-23.0

Frame (4) [B<sub>15-19-25</sub>], [B<sub>17-23-27</sub>] and [B<sub>18-24-28</sub>]:

Beams	SF <sub>1</sub> (V)	SF <sub>1</sub> (L)	SF <sub>1</sub> (D)	SF <sub>2</sub> (V)	SF <sub>2</sub> (L)	SF <sub>2</sub> (D)
B <sub>15</sub> , B <sub>17</sub> , B <sub>18</sub>	8.9	±3.5	9.3	-10.0	±3.5	-10.1
B <sub>19</sub> , B <sub>23</sub> , B <sub>24</sub>	13.3	±2.6	13.3	-13.3	±2.6	-13.3
B <sub>25</sub> , B <sub>27</sub> , B <sub>28</sub>	10.0	±3.5	10.1	-8.9	±3.5	-9.3

Beams	BM <sub>1</sub> (V)	BM <sub>1</sub> (L)	BM <sub>1</sub> (D)	BM <sub>0</sub> (V=D)	BM <sub>2</sub> (V)	BM <sub>2</sub> (L)	BM <sub>2</sub> (D)
B <sub>15</sub> , B <sub>17</sub> , B <sub>18</sub>	-16.0	±24.2	6.2, -30.2	11.0	-23.3	±21.8	-33.8
B <sub>19</sub> , B <sub>23</sub> , B <sub>24</sub>	-30.1	±18.3	-36.3	16.5	-30.1	±18.3	-36.3
B <sub>25</sub> , B <sub>27</sub> , B <sub>28</sub>	-23.3	±21.8	-33.8	11.0	-16.0	±24.2	6.2, -30.2

Other Beams:

1. Beam B<sub>22</sub> -

Approximately designed as a simply supported beam under similar load as B<sub>20</sub>.

$$\therefore \text{Maximum SF} \cong 1.06 \times 7/2 = 3.71 \text{ k}$$

$$\text{and Maximum positive BM} \cong 1.06 \times 7^2/8 = 6.49 \text{ k'}$$

2. Edge Beam for S<sub>10</sub> -

Uniformly distributed load on S<sub>10</sub> = 0.109 ksf

Uniformly distributed load on Edge Beam = 0.109 × 5' = 0.55 k'

$$\therefore \text{Clear Span} = 13' \Rightarrow V_{\max} \cong 0.55 \times (13)/2 = 3.6 \text{ k}; M^{\pm} \cong 0.55 \times (13)^2/10 = 9.3 \text{ k'}$$

## 4.2 Load Combination for Columns

The column forces are shown below as [AF (k), BM<sub>1y</sub>, BM<sub>1x</sub> (k')]

Columns	Frame	(V)	(L <sub>x</sub> )	0.75(V+L <sub>x</sub> )	0.75(V-L <sub>x</sub> )	(L <sub>y</sub> )	0.75(V+L <sub>y</sub> )	0.75(V-L <sub>y</sub> )
C <sub>1</sub> , C <sub>17</sub>	2, 4	-84.0, 5.7, 3.4	-7.9, 24.1, 0	-68.9, 22.4, 2.6	-57.1, -13.8, 2.6	-10.2, 0, 23.1	-70.7, 4.3, 19.9	-55.4, 4.3, -14.8
C <sub>2</sub> , C <sub>18</sub>	2, 3	-130.8, -1.8, 3.6	-0.8, 27.9, 0	-98.7, 19.6, 2.7	-97.5, -22.3, 2.7	-5.4, 0, 13.6	-102.2, -1.4, 12.9	-94.1, -1.4, -7.5
C <sub>3</sub> , C <sub>19</sub>	2, 4	-120.7, 0.1, 3.4	-1.2, 28.3, 0	-91.4, 21.6, 2.6	-89.6, -21.2, 2.6	-10.2, 0, 23.1	-98.2, 0.1, 19.9	-82.9, 0.1, -14.8
C <sub>4</sub> , C <sub>20</sub>	2, 4	-76.7, -4.4, 3.4	9.9, 24.7, 0	-50.1, 15.2, 2.6	-65.0, -21.8, 2.6	-10.2, 0, 23.1	-65.2, -3.3, 19.9	-49.9, -3.3, -14.8
C <sub>5</sub> , C <sub>12</sub>	1, 4	-143.5, 6.1, 1.4	-5.9, 20.0, 0	-112.1, 19.6, 1.1	-103.2, -10.4, 1.1	2.4, 0, 26.5	-105.8, 4.6, 20.9	-109.4, 4.6, -18.8
C <sub>6</sub> , C <sub>13</sub>	1, 3	-140.2, -3.7, -2.2	-13.0, 24.6, 0	-114.9, 15.7, -1.7	-95.4, -21.2, -1.7	-6.7, 0, 16.4	-110.2, -2.8, 10.7	-100.1, -2.8, -14.0
C <sub>7</sub> , C <sub>14</sub>	1	-57.8, -0.1, 0	0.1, 24.2, 0	-43.3, 18.1, 0	-43.4, -18.1, 0	0., 0, 0.	-43.4, -0.1, 0	-43.4, -0.1, 0
C <sub>8</sub> , C <sub>15</sub>	1, 4	-168.8, 1.9, -2.7	11.4, 24.9, 0	-118.1, 20.1, 1.1	-135.2, -17.3, 1.1	2.4, 0, 26.5	-124.8, 1.4, 20.9	-128.4, 1.4, -18.8
C <sub>9</sub> , C <sub>16</sub>	1, 4	-134.5, -4.6, -2.7	7.4, 20.6, 0	-95.3, 12.0, -2.0	-106.4, -18.9, -2.0	1.7, 0, 18.9	-99.6, -3.5, 12.2	-102.2, -3.5, -16.2
C <sub>10</sub>	3	-28.2, 0, 0.0	0, 0, 0	-21.2, 0, 0.0	-21.2, 0, 0.0	0., 0, 17.0	-21.2, 0.0, 12.8	-21.2, 0.0, -12.8

Besides, the design force on C<sub>11</sub> is assumed to be 3.71<sup>k</sup>; i.e., the SF at support of B<sub>22</sub>.

In this work, only one size and reinforcements will be chosen for all the columns. For this purpose, the columns (C<sub>8</sub>, C<sub>15</sub>) are chosen as the model because they provide the most critical design conditions.

The designed column should therefore satisfy the following design conditions,

- (1) Compressive Force = 168.8<sup>k</sup>, Bending Moments BM<sub>1x</sub> = 2.7 k', BM<sub>1y</sub> = 1.9 k'.
- (2) Compressive Force = 118.1<sup>k</sup>, Bending Moments BM<sub>1x</sub> = 1.1 k', BM<sub>1y</sub> = 20.1 k'.
- (3) Compressive Force = 135.2<sup>k</sup>, Bending Moments BM<sub>1x</sub> = 1.1 k', BM<sub>1y</sub> = 17.3 k'.
- (4) Compressive Force = 124.8<sup>k</sup>, Bending Moments BM<sub>1x</sub> = 20.9 k', BM<sub>1y</sub> = 1.4 k'.
- (5) Compressive Force = 128.4<sup>k</sup>, Bending Moments BM<sub>1x</sub> = 18.8 k', BM<sub>1y</sub> = 1.4 k'.

## 5. Design of Beams

### Flexural Design

As shown for Slab Design,  $n = 9$ ,  $k = 0.378$ ,  $j = 0.874$  and  $R = 0.223$  ksi

The section shown is chosen for all the beams.

∴ For 1 layer of rods,  $d = 16 - 2.5 = 13.5''$ ,  $d' = 2.5''$

$$M_c = Rbd^2 = 0.223 \times 12 \times (13.5)^2 / 12 = 40.6 \text{ k'}$$

The  $M_{\max}$  is 40.9 k' (in  $B_1$  and  $B_{12}$ )

⇒ Almost all beams are Singly Reinforced.

In the only doubly reinforced beams, the extra moment ( $40.9 - 40.6 = 0.3$  k') is negligible and expected to be absorbed within the necessary reinforcements on the other side.

$$\therefore A_s = M / f_s j d = M \times 12 / (20 \times 0.874 \times 13.5) = M / 19.67$$

For T-beams (possible for positive moments),

$$A_s = M / f_s (d - t/2) = M \times 12 / (20 \times [13.5 - 2]) = M / 19.17$$

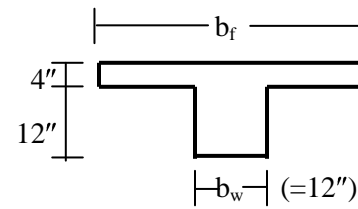

### Shear Design

$$\text{For Shear, } V_c = 1.1 \sqrt{f_c'} b_w d = 1.1 \sqrt{(3000)} \times 12 \times 13.5 / 1000 = 9.8^k$$

$$V_{c1} = 3 \sqrt{f_c'} b_w d = 26.6^k, \quad V_{c2} = 5 \sqrt{f_c'} b_w d = 44.4^k$$

The Maximum Design Shear Force here [for  $B_{19}$ ,  $B_{23}$ ,  $B_{27}$  in Frame (4)] is

$$= 13.3 - 1.90 \times (12/2 + 13.5) / 12 = 10.2^k, \text{ which is } > V_c, \text{ but } < V_{c1} \text{ and } V_{c2}.$$

$$\therefore S_{\max} = d/2 = 6.75'', 12'' \text{ or } A_v / (0.0015 b_w) = 0.22 / (0.0015 \times 12) = 12.2'' \Rightarrow S_{\max} = 6.75''$$

$$\begin{aligned} \text{Spacing of \#3 Stirrups, } S &= A_v f_v d / (V - V_c) = 0.22 \times 20 \times 13.5 / (V - 9.8) = 59.4 / (V - 9.8) \\ &= 143.5'', \text{ when } V = 10.2^k \end{aligned}$$

∴ The design is governed by  $S_{\max} = 6.75''$

The rest of the design concentrates mainly on flexural reinforcements.

Frame (1) [B<sub>4-5-6-7</sub>] and [B<sub>8-9-10-11</sub>]:  
 The design moments (k') are

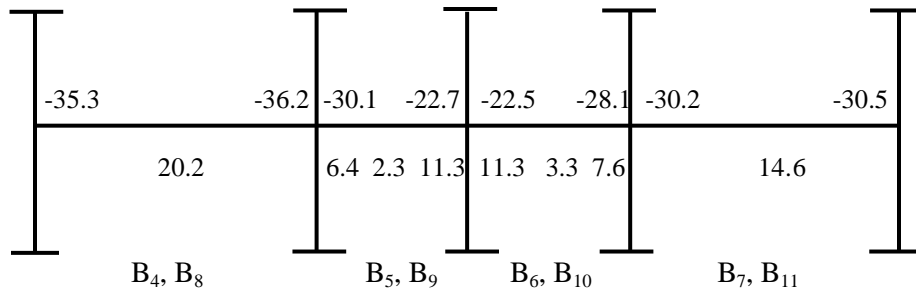

The flexural reinforcements (in<sup>2</sup>) are

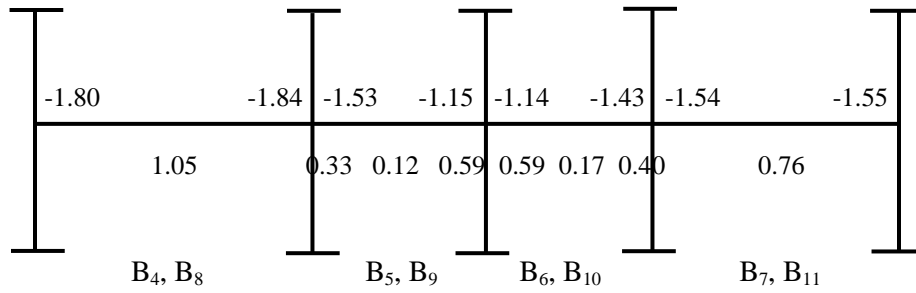

The reinforcements are arranged as follows

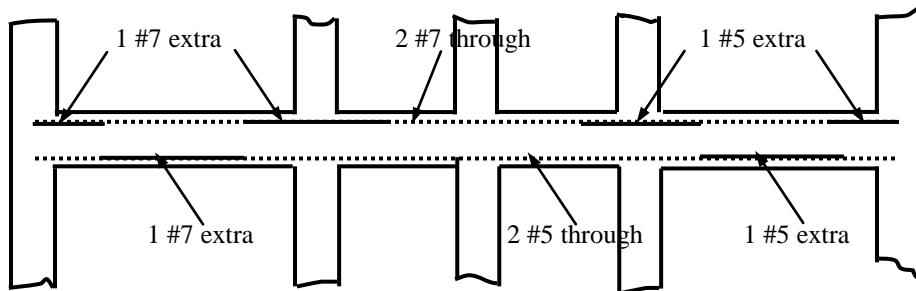



Frame (2) [B<sub>1-2-3</sub>] and [B<sub>12-13-14</sub>]:

The design moments (k') are

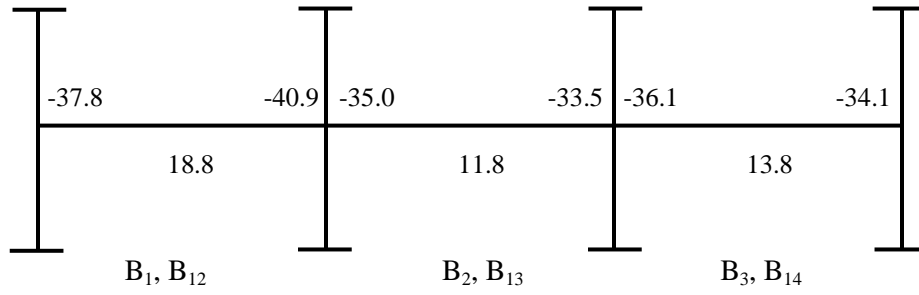

The flexural reinforcements (in<sup>2</sup>) are

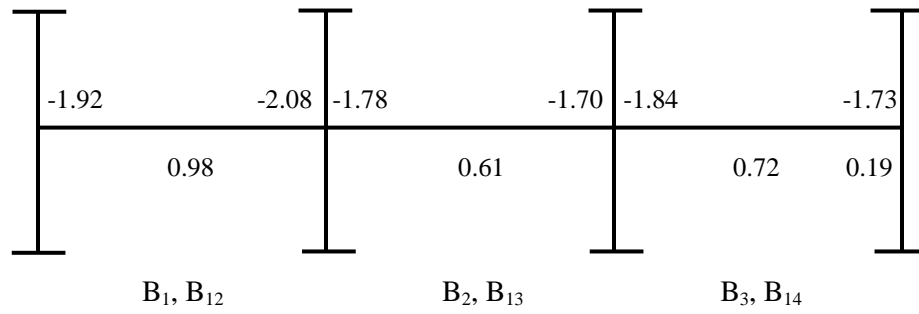

The reinforcements are arranged as follows

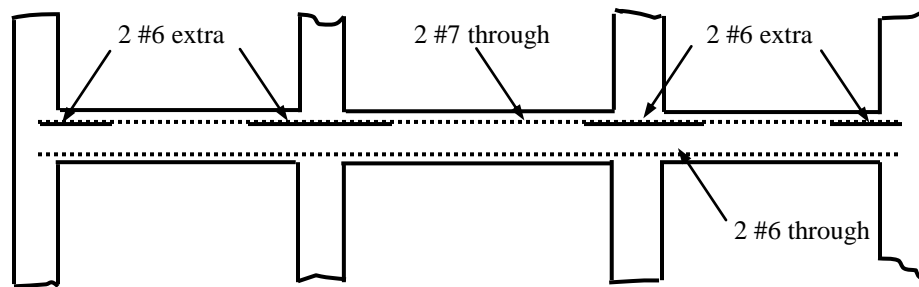

Frame (3) [B<sub>16-20-21-26</sub>]:

The design moments (k') are

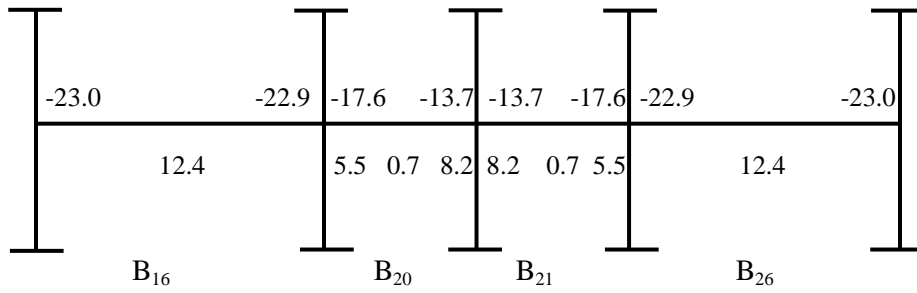

The flexural reinforcements (in<sup>2</sup>) are

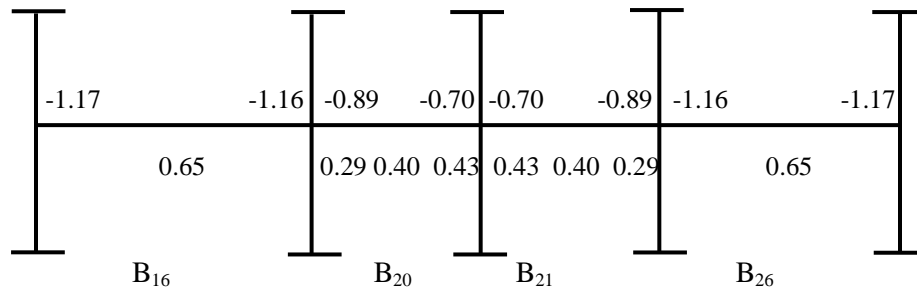

The reinforcements are arranged as follows

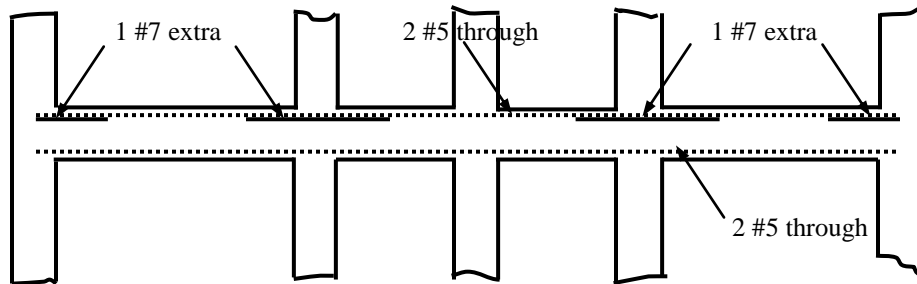

Frame (4) [B<sub>15-17-18</sub>], [B<sub>17-23-27</sub>] and [B<sub>25-27-28</sub>]:

The design moments (k') are

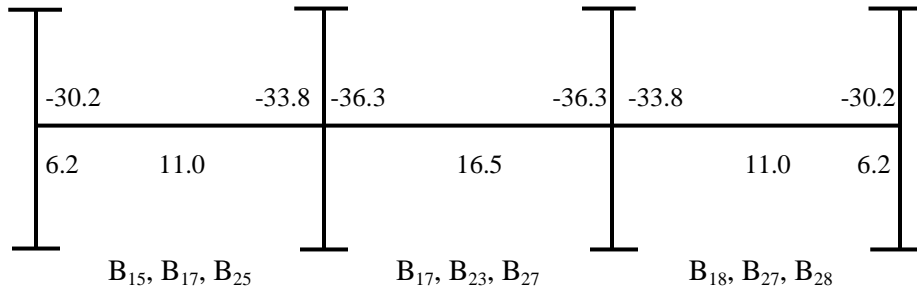

The flexural reinforcements (in<sup>2</sup>) are

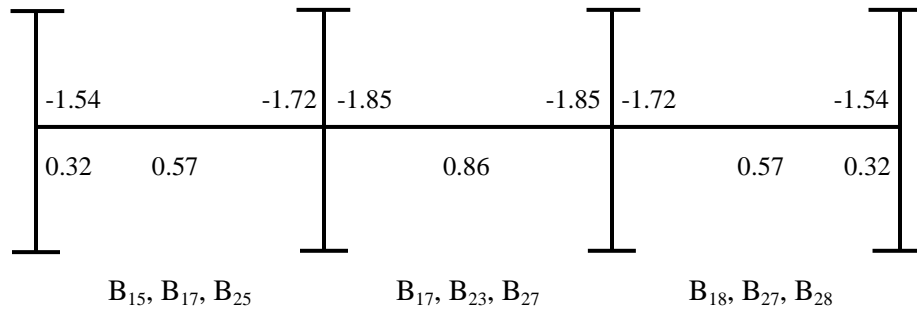

The reinforcements are arranged as follows

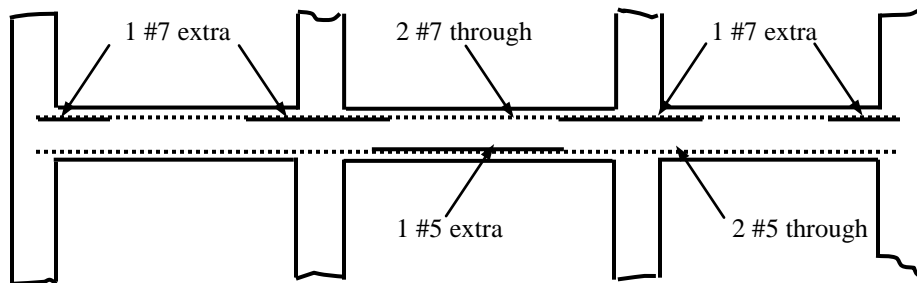

## 6. Design of Columns

The designed column should satisfy the five design conditions mentioned before (in the load combination for columns).

- (1) Compressive Force = 168.8<sup>k</sup>, Bending Moments  $BM_{1x} = 2.7 \text{ k'}$ ,  $BM_{1y} = 1.9 \text{ k'}$
- (2) Compressive Force = 118.1<sup>k</sup>, Bending Moments  $BM_{1x} = 1.1 \text{ k'}$ ,  $BM_{1y} = 20.1 \text{ k'}$
- (3) Compressive Force = 135.2<sup>k</sup>, Bending Moments  $BM_{1x} = 1.1 \text{ k'}$ ,  $BM_{1y} = 17.3 \text{ k'}$
- (4) Compressive Force = 124.8<sup>k</sup>, Bending Moments  $BM_{1x} = 20.9 \text{ k'}$ ,  $BM_{1y} = 1.4 \text{ k'}$
- (5) Compressive Force = 128.4<sup>k</sup>, Bending Moments  $BM_{1x} = 18.8 \text{ k'}$ ,  $BM_{1y} = 1.4 \text{ k'}$

To choose an assumed section, it will be designed only for an axial force slightly greater than the first of those conditions [since condition (1) has additional moments also]; and the design will be checked against the other conditions.

Assume the design axial load = 175<sup>k</sup>

The following formula is valid for tied columns

$$175 = 0.85 (0.25f'_c A_g + A_s f_s) = 0.85 A_g (0.25 f'_c + p_g f_s)$$

$$\therefore p_g = 0.03 \Rightarrow 175 = 0.85 A_g (0.25 \times 3 + 0.03 \times 20)$$

$$\Rightarrow A_g = 152.21 \text{ in}^2$$

$\therefore$  Choose (12"×13") section with 10 #6 bars and #3 ties @12" c/c.

$$\therefore p_g = 4.4 / (12 \times 13) = 0.028, m = f_y / 0.85 f'_c = 40 / 2.55 = 15.69$$

$\therefore$  The column has two axes with different dimensions and steel arrangements

For the strong axis, load eccentricity for balanced condition,

$$e_{bx} = (0.67 p_g m + 0.17) d = (0.67 \times 0.028 \times 15.69 + 0.17) \times (13 - 2.5) = 4.90'' = 0.41'$$

For the weak axis, load eccentricity for balanced condition,

$$e_{by} = (0.67 p_g m + 0.17) d = (0.67 \times 0.028 \times 15.69 + 0.17) \times (12 - 2.5) = 4.43'' = 0.37'$$

All the eccentricities involved here are much less than  $e_{bx}$  and  $e_{by}$ , so compression governs in each case.

$$S_x = (1/c) [bh^3/12 + (2n-1)\sum A_{si} (h_i - h/2)^2]$$

$$= (1/6.5) [12 \times 13^3 / 12 + (2 \times 9 - 1) \times 2 \times \{1.32 \times (4.0)^2 + 0.88 \times (1.0)^2\}] = 453.1 \text{ in}^3$$

$$S_y = (1/6.0) [13 \times 12^3 / 12 + (2 \times 9 - 1) \times 2 \times \{1.76 \times (3.5)^2 + 0.44 \times (0)^2\}] = 434.2 \text{ in}^3$$

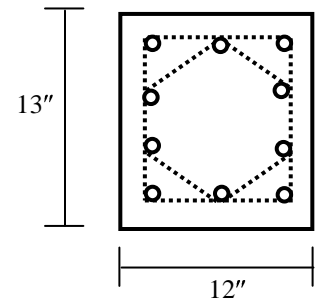

For condition (1)

$$f_a = P/A_g = 168.8/156 = 1.08 \text{ ksi}, F_a = 0.34(1+p_g m)f_c' = 0.34(1+0.028 \times 15.69) \times 3 = 1.47 \text{ ksi},$$

$$f_{bx} = M_x/S_x, F_{bx} = 0.45f_c' = 1.35 \text{ ksi}, f_{by} = M_y/S_y, F_{by} = 0.45f_c' = 1.35 \text{ ksi}$$

$$\therefore f_a/F_a + f_{bx}/F_{bx} + f_{by}/F_{by} = 1.08/1.47 + (2.7 \times 12/453.1)/1.35 + (1.9 \times 12/434.2)/1.35$$

$$= 0.74 + 0.05 + 0.04 = 0.83 < 1 \text{ (OK)}$$

$\therefore$  Condition (1) is satisfied.

For condition (2)

$$(118.1/156)/1.47 + (1.1 \times 12/453.1)/1.35 + (20.1 \times 12/434.2)/1.35$$

$$= 0.51 + 0.02 + 0.41 = 0.95 < 1 \text{ (OK)}$$

$\therefore$  Condition (2) is satisfied.

For condition (3)

$$(135.2/156)/1.47 + (1.1 \times 12/453.1)/1.35 + (17.3 \times 12/434.2)/1.35$$

$$= 0.59 + 0.02 + 0.35 = 0.96 < 1 \text{ (OK)}$$

$\therefore$  Condition (3) is satisfied.

For condition (4)

$$(124.8/156)/1.47 + (20.9 \times 12/453.1)/1.35 + (1.4 \times 12/434.2)/1.35$$

$$= 0.54 + 0.41 + 0.03 = 0.98 < 1 \text{ (OK)}$$

$\therefore$  Condition (4) is satisfied.

For condition (5)

$$(128.4/156)/1.47 + (18.8 \times 12/453.1)/1.35 + (1.4 \times 12/434.2)/1.35$$

$$= 0.56 + 0.37 + 0.03 = 0.96 < 1 \text{ (OK)}$$

$\therefore$  Condition (5) is satisfied.

$\therefore$  The assumed section is chosen for all the columns.

## 7. Design of Footings

The following sample footings will be designed.

1. Individual Footing: A footing under  $C_5$  will be designed for column load  $143.5^k$  (plus footing weight).
2. Combined Footing: A footing under  $C_6$ ,  $C_7$  and  $C_8$  will be designed for column loads  $140.2^k$ ,  $57.8^k$  and  $168.8^k$  (plus footing weights) combined.

The allowable bearing capacity of the soil is 2.0 ksf

[This can be determined from field tests like SPT, CPT or from lab test for unconfined compression strength. The formula for bearing capacity has factors for soil cohesion ( $N_c$ ), foundation width ( $N_\gamma$ ) and depth ( $N_q$ ). These are functions of the angle of friction  $\phi$ . With a factor of safety 3.0,  $N_c$  approximately equals to 6.0 and neglecting  $N_\gamma$  and  $N_q$ , the unconfined compression strength equals to the allowable bearing capacity].

### Individual Footing under $C_5$ :

Column load =  $143.5^k \Rightarrow$  Footing load  $\cong 143.5^k \times 1.1 \cong 157.9^k$

$\therefore$  Footing area =  $157.9^k / 2.0 \text{ ksf} = 78.9 \text{ ft}^2 \cong 9.00' \times 9.00'$

$\therefore$  Effective bearing pressure =  $143.5 / (9.00)^2 = 1.77 \text{ ksf}$

Column size =  $12'' \times 13''$ , Effective depth of footing =  $d$

$\therefore$  Punching Shear area  $A_p = 2 \times (12 + d + 13 + d) d = 4 \times (12.5 + d) d$

Punching Shear strength =  $2\sqrt{f'_c} = 2\sqrt{3000} = 110 \text{ psi} = 0.110 \text{ ksi}$

$\therefore 0.110 \{4 \times (12.5 + d) d\} = 143.5 - 1.77 \times (12+d) \times (13+d) / (12)^2$

$\Rightarrow d^2 + 12.5 d = 327.5 - (12+d) \times (13+d) / 35.62 \Rightarrow d = 12.09''$

$\therefore$  Take footing thickness,  $t = 16.5'' \Rightarrow d = 12.5''$

Flexural Shear strength =  $1.1\sqrt{f'_c} = 1.1\sqrt{3000} = 60.2 \text{ psi} = 0.0602 \text{ ksi} = 8.68 \text{ ksf}$

Maximum flexural shear force =  $1.77 \text{ ksf} \times \{(9.00 - 12/12) / 2 - d\}' = 1.77 \times (4.0 - d) \text{ k}'$

$\therefore 8.68 \times 1 \times d = 1.77 \times (4.0 - d) \Rightarrow d = 1.77 \times 4.0 / (8.68 + 1.77) = 0.68' = 8.14'' < 12.5''$ , OK.

Total Maximum bending moment,  $M = 1.77 \times \{(9.00 - 12/12) / 2\}^2 / 2 \times 9.00 = 127.56 \text{ k}'$

$\therefore$  Depth required by M is =  $\sqrt{M/R_b} = \sqrt{\{127.56 / (0.223 \times 9.00)\}} = 7.97'' < 12.5''$ , OK.

$\therefore A_s = M / f_y j d = 127.56 \times 12 / (20 \times 0.874 \times 12.5) = 7.01 \text{ in}^2$

Minimum reinforcement =  $(0.2 / f_y) b d = (0.2 / 40) \times 9.00 \times 12 \times 12.5 = 6.75 \text{ in}^2 < A_s$

$\therefore$  Provide 12 #7 bars in each direction.

Combined Footing under C<sub>6</sub>-C<sub>7</sub>-C<sub>8</sub>:

Column loads are 140.2<sup>k</sup>, 57.8<sup>k</sup> and 168.8<sup>k</sup>

∴ Resultant = 140.2 + 57.8 + 168.8 = 366.8<sup>k</sup>

∴ Footing area = 366.8<sup>k</sup> × 1.1/2.0 ksf = 201.74 ft<sup>2</sup> ≈ 20' × 10'

Distance of resultant from the first column

= (140.2 × 0 + 57.8 × 7 + 168.8 × 14) / 366.8 = 7.55'

∴ Effective bearing pressure = 366.8 / (20 × 10) = 1.834 ksf; i.e., 18.34 k/' along the length.

∴ Considering the column loads to be uniformly distributed over the column width = 1', the footing loads and corresponding SFD and BMD are shown below

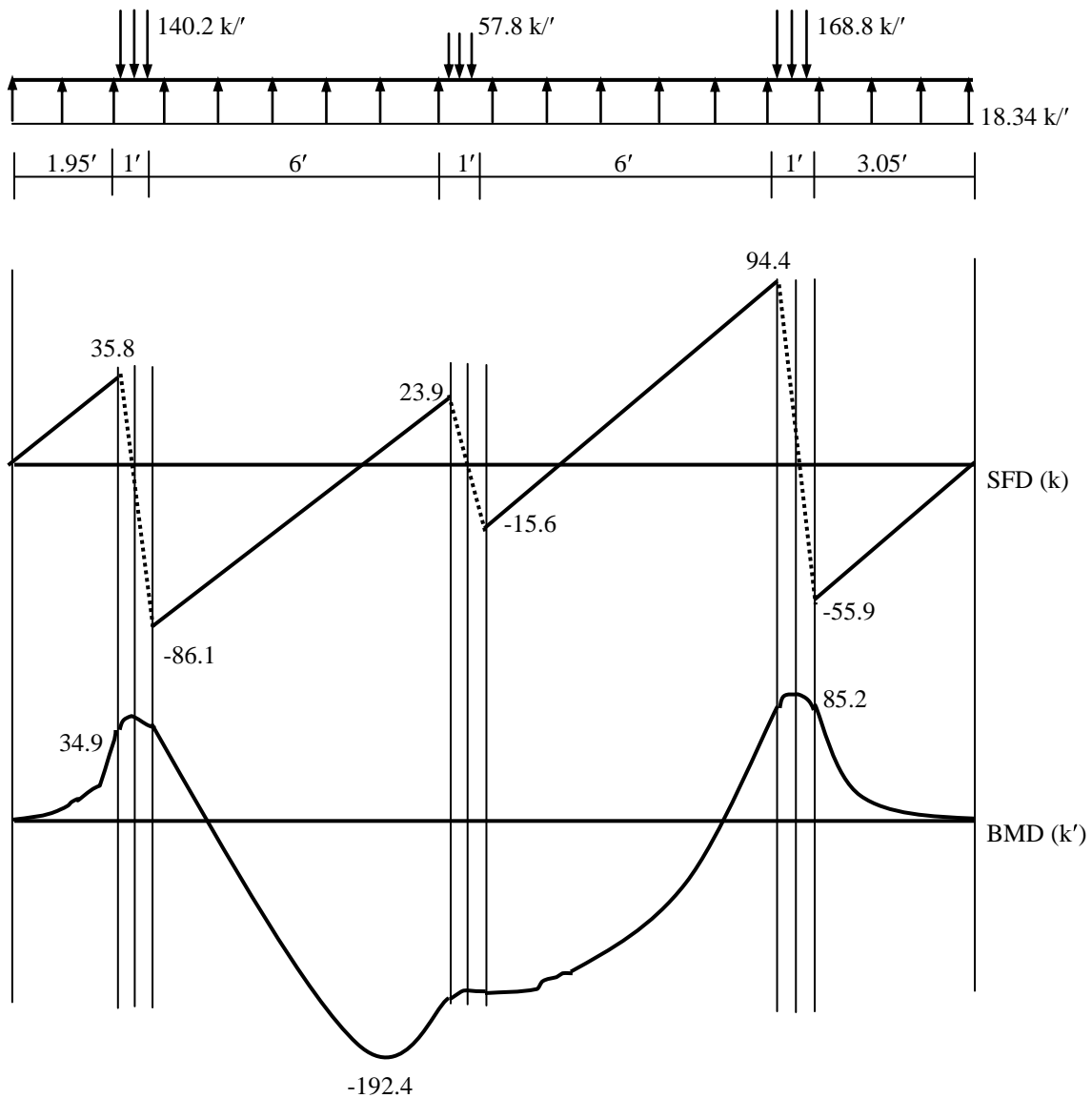

Column size = 12"×13", Effective depth of footing = d

∴ Punching Shear area  $A_p = 2 \times (12 + d + 13 + d) d = 4 \times (12.5 + d) d$

Punching Shear strength =  $2\sqrt{f_c'} = 110 \text{ psi} = 0.110 \text{ ksi}$

∴  $0.110\{4 \times (12.5 + d) d\} = 168.8 - 1.834 \times (12 + d) \times (13 + d) / (12)^2$

⇒  $d^2 + 12.5 d = 445.5 - (12 + d) \times (13 + d) / 34.57 \Rightarrow d = 15.55''$

∴ Take footing thickness,  $t = 20'' \Rightarrow d = 16''$

Flexural Shear strength =  $1.1\sqrt{f_c'} = 60.2 \text{ psi} = 0.0602 \text{ ksi} = 8.68 \text{ ksf}$

Maximum shear force (according to SFD) =  $94.4^k$

∴ Maximum flexural shear force =  $94.4 - 18.25d$  [d is in ft]

∴  $8.68 \times 10 \times d = 94.4 - 18.25d \Rightarrow d = 0.899' = 10.78'' < 16''$ , OK.

Maximum bending moment (according to BMD) =  $192.4 \text{ k'}$

∴ Depth required by M is =  $\sqrt{M/Rb} = \sqrt{\{192.4 / (0.223 \times 10)\}} = 9.29'' < 16''$ , OK.

∴  $A_s^{(+)} = M / f_s j d = 192.4 \times 12 / (20 \times 0.874 \times 16) = 192.4 / 23.3 = 8.26 \text{ in}^2$ , at top

and  $A_s^{(-)} = 85.2 / 23.3 = 3.66 \text{ in}^2$ , at bottom

Minimum reinforcement =  $(0.2 / f_y) b d = (0.2 / 40) \times 10 \times 12 \times 16 = 9.60 \text{ in}^2 > A_s$

∴ Provide 16 #7 bars at top and bottom.

Width of the transverse beams under columns =  $12 + 16 = 28''$

Load per unit length under  $C_8 = 168.8 / 10 = 16.88 \text{ k'}$

∴ Maximum bending moment =  $16.88 \times [(10 - 13/12) / 2]^2 / 2 = 167.76 \text{ k'}$

∴ Depth required by M is =  $\sqrt{M/Rb} = \sqrt{\{167.76 \times 12 / (0.223 \times 28)\}} = 17.96'' > 16''$ .

∴ Provide  $d = 18''$ , increase the thickness to  $22''$  and put transverse rods at bottom

∴  $A_s^{(+)} = 167.76 \times 12 / (20 \times 0.874 \times 18) = 6.40 \text{ in}^2$ , at bottom [Note:  $d = 18''$  here]

Similarly,  $A_s^{(+)}$  under  $C_6 = 6.40 \times 140.2 / 168.8 = 5.31 \text{ in}^2$

and  $A_s^{(+)}$  under  $C_7 = 6.40 \times 57.8 / 168.8 = 2.19 \text{ in}^2$

∴  $A_{s(\min)} = (0.2 / f_y) b d = (0.2 / 40) \times 28 \times 18 = 2.52 \text{ in}^2 < A_s^{(+)}$  for all columns except  $C_7$

∴ Provide 9#7, 5#7 and 11#7 bars at bottom within the width of the transverse beams (28'') under each column (in placing 11 #7 bars in 28'', be careful about minimum spacing).

Elsewhere, provide  $(0.2 / f_y) b d = 1.08 \text{ in}^2 / \text{ft}$  (i.e., #7 @ 6.5'' c/c).



Details of Individual Footing

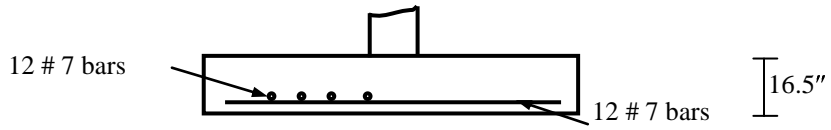
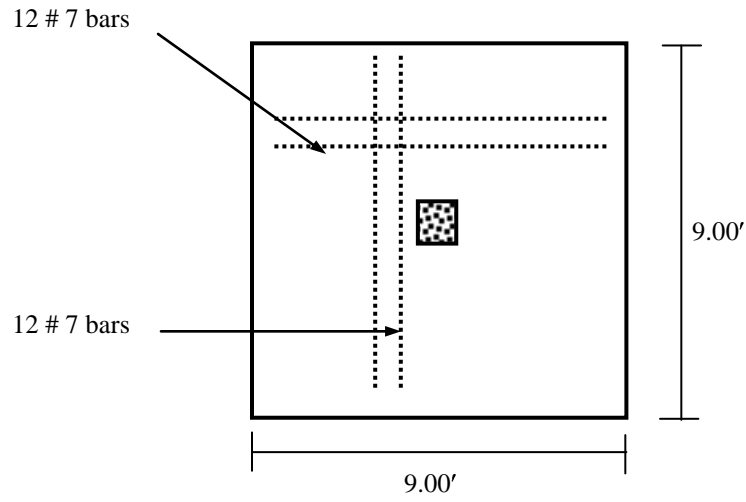

Details of Combined Footing

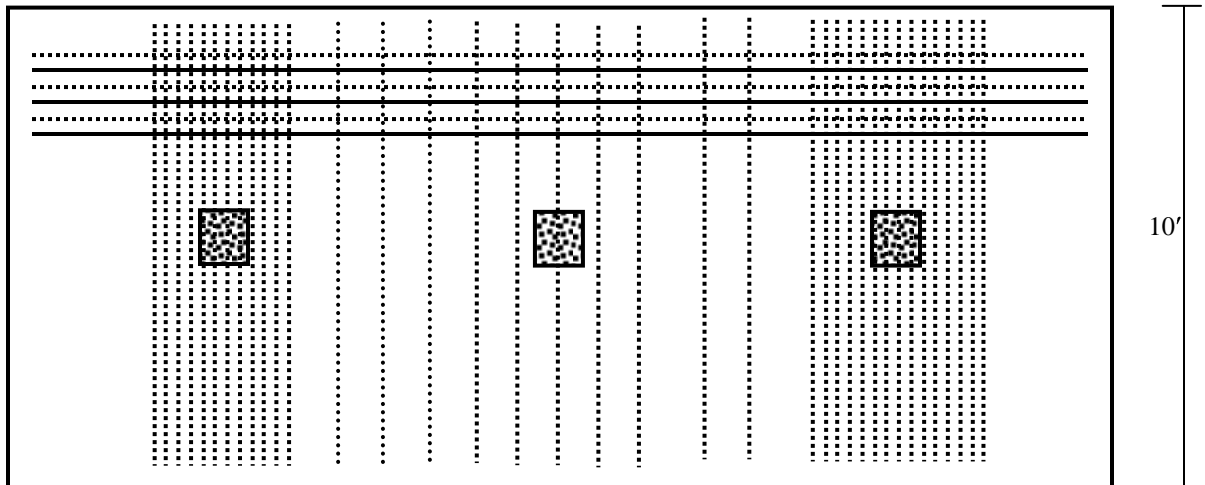
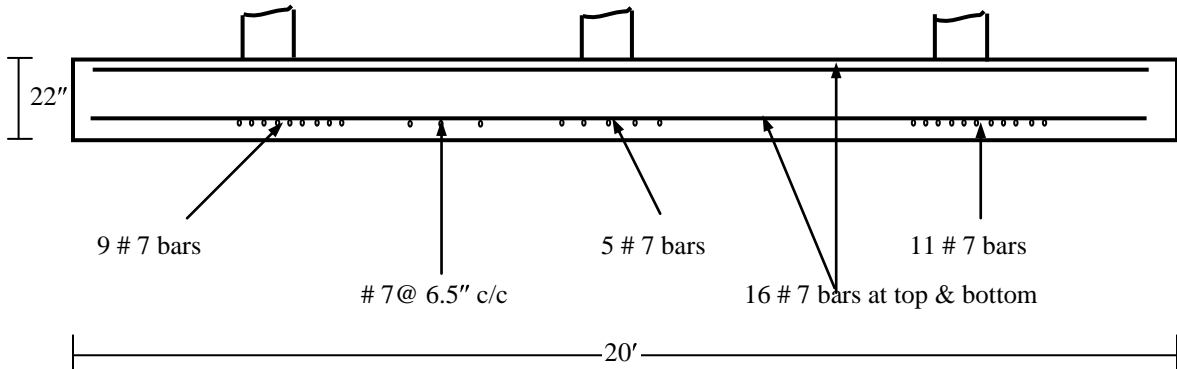

## 5. Design of Beams (USD)

Material Properties:  $f'_c = 3$  ksi,  $f_y = 40$  ksi,  $\therefore f_c = 0.85f'_c = 2.55$  ksi

### Flexural Design

$$p_{\max} = (0.75 \alpha f'_c / f_y) [87 / (87 + f_y)] = 0.0277, R_u = \phi p_{\max} f_y [1 - 0.59 p_{\max} f_y / f'_c] = 0.781 \text{ ksi}$$

The section shown is chosen for all the beams.

$\therefore$  For 1 layer of rods,  $d = 16 - 2.5 = 13.5''$ ,  $d' = 2.5''$

$$M_c = R_u b d^2 = 0.781 \times 12 \times (13.5)^2 / 12 = 142.3 \text{ k'}$$

The  $M_{\max}$  is 61.4 k' (in  $B_1$  and  $B_{12}$ )

$\Rightarrow$  All the beams are Singly Reinforced.

$$\begin{aligned} A_s &= (f_c / f_y) [1 - \sqrt{1 - 2M / (\phi f_c b d^2)}] b d \\ &= (2.55 / 40) \times [1 - \sqrt{1 - 2M \times 12 / (0.9 \times 2.55 \times 12 \times 13.5^2)}] \times 12 \times 13.5 \\ &= 10.33 [1 - \sqrt{1 - M / 209.1}] \end{aligned}$$

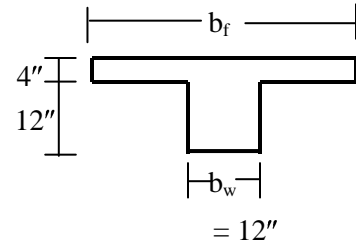

For T-beams (possible for positive moments),  $b_f$  is the minimum of

(i)  $16t_f + b_w = 76''$ , (ii) Simple Span/4  $\cong 0.6L \times 12/4 = 1.8L(')$ , (iii) c/c

$\Rightarrow$  Since  $L$  varies between  $7' \sim 18'$  and c/c between  $16' \sim 18'$ , it is conservative and simplified to assume  $b_f = 12''$ ; i.e., calculations are similar to rectangular beam.

### Shear Design

$$V_c = 2\sqrt{f'_c} b_w d = 2\sqrt{3000} \times 12 \times 13.5 / 1000 = 17.7^k$$

$$V_{c1} = 6\sqrt{f'_c} b_w d = 53.2^k, V_{c2} = 10\sqrt{f'_c} b_w d = 88.7^k$$

The Maximum Design Shear Force here [for  $B_{19}$ ,  $B_{23}$ ,  $B_{27}$  in Frame (4)] is

$$V_d = 20.3 - 2.85 \times (12/2 + 13.5) / 12 = 15.3^k \Rightarrow V_n = V_d / \phi = 18.4^k$$

$\therefore V_n > V_c$ , but  $< V_{c1}$  and  $V_{c2}$ .

$$\therefore S_{\max} = d/2 = 6.75'', 24'' \text{ or } A_v f_y / 50 b_w = 0.22 \times 40000 / (50 \times 12) = 14.7'' \Rightarrow S_{\max} = 6.75''$$

$$\begin{aligned} \text{Spacing of \#3 Stirrups, } S &= A_v f_y d / (V_n - V_c) = 0.22 \times 40 \times 13.5 / (V_n - 17.7) = 118.8 / (V_n - 17.7) \\ &= 169.7'', \text{ when } V = 18.4^k \end{aligned}$$

$\therefore$  The design is governed by  $S_{\max} = 6.75''$

The rest of the design concentrates mainly on flexural reinforcements.

Frame (1) [B<sub>4-5-6-7</sub>] and [B<sub>8-9-10-11</sub>]:

The design moments (k') are

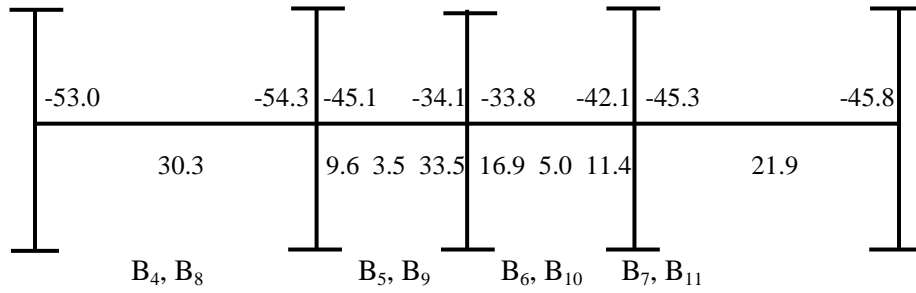

The flexural reinforcements (in<sup>2</sup>) are

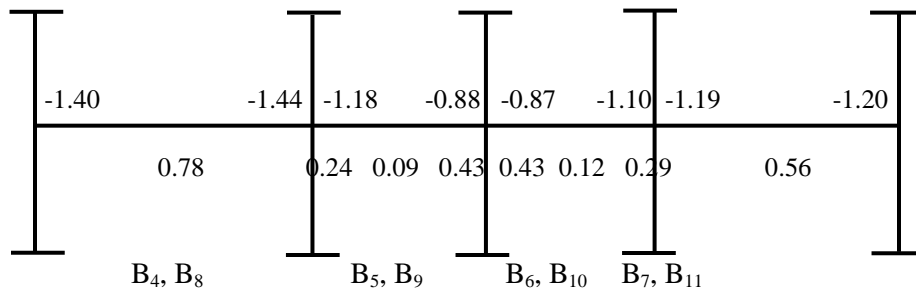

The reinforcements are arranged as follows

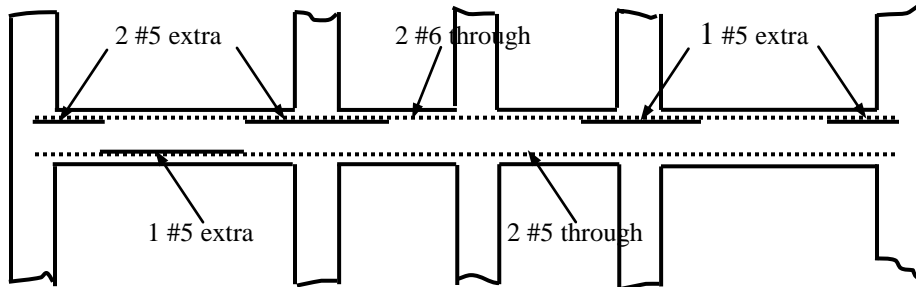

## 6. Design of Columns (USD)

The designed column should satisfy the five design conditions mentioned before (in the load combination for columns).

- (1) Compressive Force = 253.2<sup>k</sup>, Bending Moments  $BM_{1x} = 4.1$  k',  $BM_{1y} = 2.8$  k'
- (2) Compressive Force = 177.1<sup>k</sup>, Bending Moments  $BM_{1x} = 1.7$  k',  $BM_{1y} = 30.1$  k'
- (3) Compressive Force = 202.8<sup>k</sup>, Bending Moments  $BM_{1x} = 1.7$  k',  $BM_{1y} = 25.9$  k'
- (4) Compressive Force = 187.2<sup>k</sup>, Bending Moments  $BM_{1x} = 31.4$  k',  $BM_{1y} = 2.1$  k'
- (5) Compressive Force = 192.6<sup>k</sup>, Bending Moments  $BM_{1x} = 28.2$  k',  $BM_{1y} = 2.1$  k'

To choose an assumed section, it will be designed only for an axial force slightly greater than the first of those conditions [since condition (1) has additional moments also]; and the design will be checked against the other conditions.

Assume the design axial load = 265<sup>k</sup>

The following formula is valid for tied columns, using  $f_c = 0.85 f_c'$

$$265 = 0.80\phi (0.85f_c' A_c + A_s f_y) = 0.80\phi A_g \{f_c + p(f_y - f_c)\}$$

$$\therefore p = 0.03 \Rightarrow 265 = 0.80 \times 0.70 A_g (0.85 \times 3 + 0.03 \times 37.45)$$

$$\Rightarrow A_g = 128.82 \text{ in}^2$$

$\therefore$  Choose (11"×12") section with 8 #6 bars and #3 ties @ 11" c/c.

$$\therefore p = 3.52 / (11 \times 12) = 0.027, \mu = f_y / 0.85f_c' = 40 / 2.55 = 15.69$$

Use interaction diagram for rectangular columns with

$$\gamma = 0.60, \text{ and } p\mu = 0.027 \times 15.69 = 0.42,$$

$$\phi f_c' b h = 0.7 \times 3 \times 11 \times 12 = 277.2^k, \phi f_c' b h^2 = 3326.4 \text{ k}'' = 277.2 \text{ k}', \phi f_c' h b^2 = 254.1 \text{ k}'$$

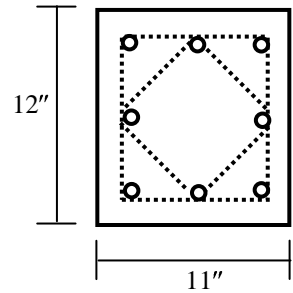

For condition (1)

$$k = P / (\phi f_c' b h) = 253.2 / 277.2 = 0.91$$

$$k_0 = 1.18$$

$$k e_x / h = M_x / (\phi f_c' b h^2) = 4.1 / 277.2 = 0.015 \Rightarrow k_x = 1.15$$

$$k e_y / h = M_y / (\phi f_c' h b^2) = 2.8 / 254.1 = 0.011 \Rightarrow k_y = 1.16$$

$$\therefore \text{Reciprocal method} \Rightarrow 1/k_{xy} = 1/k_x + 1/k_y - 1/k_0 = 1/1.15 + 1/1.16 - 1/1.18$$

$$\Rightarrow k_{xy} = 1.13, \text{ which is } > k (= 0.91) \text{ (OK)}$$

$\therefore$  Condition (1) is satisfied.

For condition (2)

$$k = P/(\phi f_c' bh) = 177.1/277.2 = 0.64$$

$$k_0 = 1.18; k_{e_x}/h = 0.006 \Rightarrow k_x = 1.17; k_{e_y}/h = 0.118 \Rightarrow k_y = 0.84$$

$$\therefore \text{Reciprocal method} \Rightarrow 1/k_{xy} = 1/k_x + 1/k_y - 1/k_0 = 1/1.17 + 1/0.84 - 1/1.18$$

$$\Rightarrow k_{xy} = 0.83, \text{ which is } > k (= 0.64) \text{ (OK)}$$

$\therefore$  Condition (2) is satisfied.

For condition (3)

$$k = P/(\phi f_c' bh) = 202.8/277.2 = 0.73$$

$$k_0 = 1.18; k_{e_x}/h = 0.006 \Rightarrow k_x = 1.17; k_{e_y}/h = 0.102 \Rightarrow k_y = 0.90$$

$$\therefore \text{Reciprocal method} \Rightarrow 1/k_{xy} = 1/k_x + 1/k_y - 1/k_0 = 1/1.17 + 1/0.90 - 1/1.18$$

$$\Rightarrow k_{xy} = 0.89, \text{ which is } > k (= 0.73) \text{ (OK)}$$

$\therefore$  Condition (3) is satisfied.

For condition (4)

$$k = P/(\phi f_c' bh) = 187.2/277.2 = 0.68$$

$$k_0 = 1.18; k_{e_x}/h = 0.113 \Rightarrow k_x = 0.87; k_{e_y}/h = 0.008 \Rightarrow k_y = 1.17$$

$$\therefore \text{Reciprocal method} \Rightarrow 1/k_{xy} = 1/k_x + 1/k_y - 1/k_0 = 1/0.87 + 1/1.17 - 1/1.18$$

$$\Rightarrow k_{xy} = 0.86, \text{ which is } > k (= 0.68) \text{ (OK)}$$

$\therefore$  Condition (4) is satisfied.

For condition (5)

$$k = P/(\phi f_c' bh) = 192.6/277.2 = 0.69$$

$$k_0 = 1.18; k_{e_x}/h = 0.102 \Rightarrow k_x = 0.90; k_{e_y}/h = 0.008 \Rightarrow k_y = 1.17$$

$$\therefore \text{Reciprocal method} \Rightarrow 1/k_{xy} = 1/k_x + 1/k_y - 1/k_0 = 1/0.90 + 1/1.17 - 1/1.18$$

$$\Rightarrow k_{xy} = 0.89, \text{ which is } > k (= 0.69) \text{ (OK)}$$

$\therefore$  Condition (5) is satisfied.

$\therefore$  The assumed section is chosen for all the columns.

## 7. Design of Footings (USD)

The following sample footings will be designed.

1. Individual Footing: A footing under C<sub>5</sub> will be designed for column load 215.3<sup>k</sup> (plus footing weight).
2. Combined Footing: A footing under C<sub>6</sub>, C<sub>7</sub> and C<sub>8</sub> will be designed for column loads 210.3<sup>k</sup>, 86.7<sup>k</sup> and 253.2<sup>k</sup> (plus footing weights) combined.

The allowable bearing capacity of the soil is 2.0 ksf

[This can be determined from field tests like SPT, CPT or from lab test for unconfined compression strength. The formula for bearing capacity has factors for soil cohesion (N<sub>c</sub>), foundation width (N<sub>γ</sub>) and depth (N<sub>q</sub>). These are functions of the angle of friction φ. With a factor of safety 3.0, N<sub>c</sub> approximately equals to 6.0 and neglecting N<sub>γ</sub> and N<sub>q</sub>, the unconfined compression strength equals to the allowable bearing capacity].

### Individual Footing under C<sub>5</sub>:

Column load = 215.3<sup>k</sup> ⇒ Footing load ≅ 215.3<sup>k</sup> × 1.1 ≅ 236.8<sup>k</sup>

∴ Footing area (based on working stresses) = 236.8/2.0 ksf = 118.4 ft<sup>2</sup> ≅ 9.00' × 9.00'

∴ Effective bearing pressure = 215.3/(9.00)<sup>2</sup> = 2.66 ksf

Column size = 11"×12", Effective depth of footing = d

∴ Punching Shear area A<sub>p</sub> = 2 × (11 + d + 12 + d) d = 4 × (11.5 + d) d

Punching Shear strength = 4φ√(f'<sub>c</sub>) = 4 × 0.85√(3000) = 186 psi = 0.186 ksi

∴ 0.186 {4 × (11.5 + d) d} = 215.3 – 2.66 × (11 + d) × (12 + d)/(12)<sup>2</sup>

⇒ d<sup>2</sup> + 11.5 d = 289.0 – (11 + d) × (12 + d)/40.36 ⇒ d = 11.22"

∴ Take footing thickness, t = 15.5" ⇒ d = 11.5"

Flexural Shear strength = 2φ√(f'<sub>c</sub>) = 2 × 0.85√(3000) = 93.1 psi = 13.41 ksf

Maximum flexural shear force = 2.66 ksf × {(9.00–11/12)/2–d}' = 2.66 × (4.04–d) k'

∴ 13.41 × 1 × d = 2.66 × (4.04–d) ⇒ d = 2.66 × 4.04 / (13.41 + 2.66) = 0.67' = 8.02" < 11.5", OK.

Total Maximum bending moment, M = 2.66 × {(9.00–11/12)/2}<sup>2</sup> / 2 × 9.00 = 195.34 k'

∴ Depth required by M is = √(M/R<sub>b</sub>) = √{195.34/(0.781 × 9.00)} = 5.27" < 11.5", OK.

∴ A<sub>s</sub> = (f<sub>c</sub>/f<sub>y</sub>) [1 – √{1 – 2M/(φf<sub>c</sub>bd<sup>2</sup>)}] bd = 5.88 in<sup>2</sup>

Minimum reinforcement = (0.2/f<sub>y</sub>)bd = (0.2/40) × 9.00 × 12 × 11.5 = 6.21 in<sup>2</sup> > A<sub>s</sub>

∴ Provide 11 #7 bars in each direction.

Combined Footing under C<sub>6</sub>-C<sub>7</sub>-C<sub>8</sub>:

Column loads are 210.3<sup>k</sup>, 86.7<sup>k</sup> and 253.2<sup>k</sup>

∴ Resultant = 210.3 + 86.7 + 253.2 = 550.2<sup>k</sup>

∴ Footing area (based on working stresses) = 366.8<sup>k</sup> × 1.1/2.0 ksf = 201.74 ft<sup>2</sup> ≈ 20' × 10'

Distance of resultant from the first column

= (210.3 × 0 + 86.7 × 7 + 253.2 × 14) / 550.2 = 7.55'

∴ Effective bearing pressure = 550.2 / (20 × 10) = 2.751 ksf; i.e., 27.51 k/' along the length.

∴ Considering the column loads to be uniformly distributed over the column width = 1', the footing loads and corresponding SFD and BMD are shown below

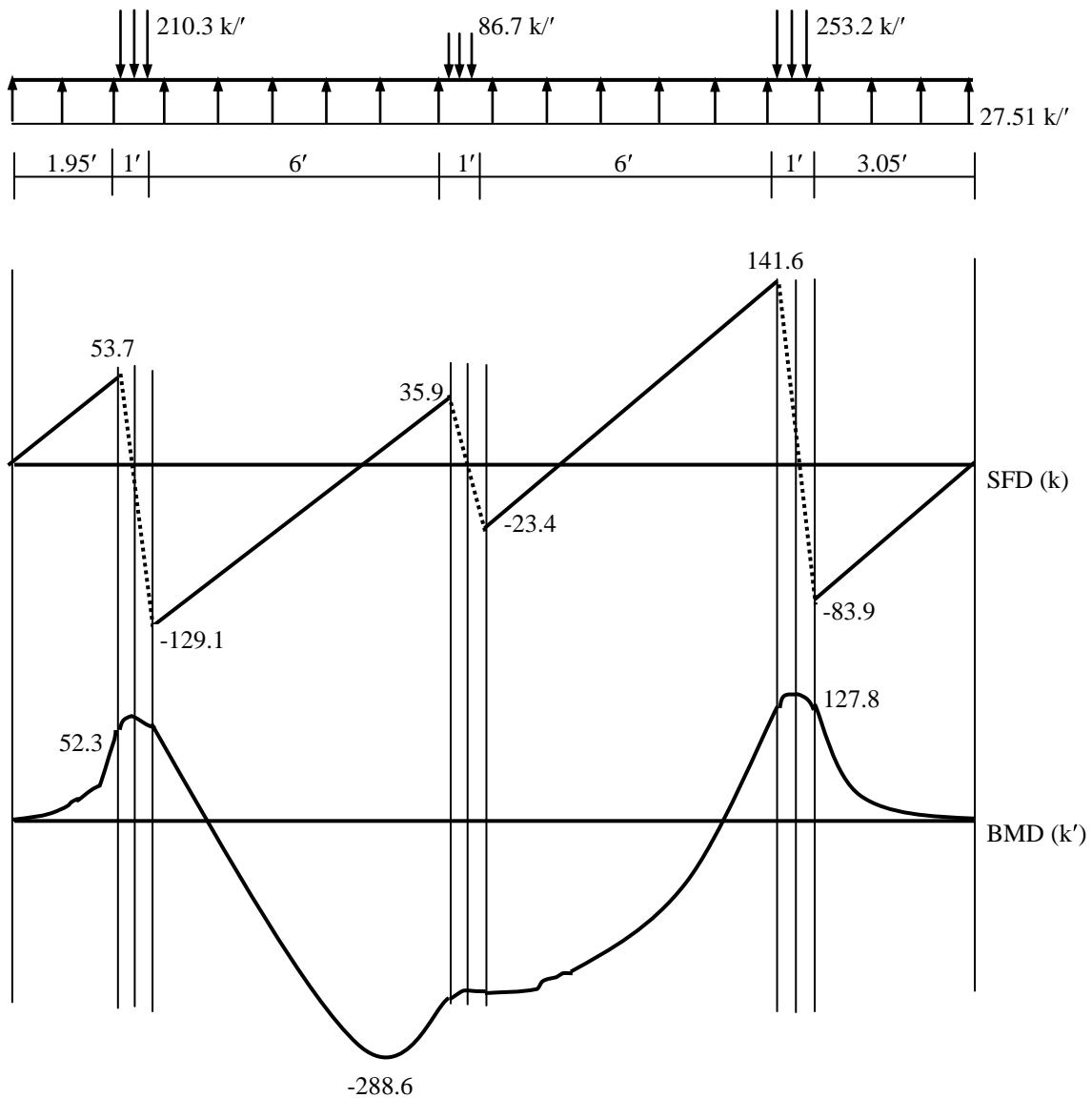

Column size = 11"×12", Effective depth of footing = d

$$\therefore \text{Punching Shear area } A_p = 2 \times (11 + d + 12 + d) d = 4 \times (11.5 + d) d$$

$$\text{Punching Shear strength} = 4\phi\sqrt{f_c'} = 4 \times 0.85\sqrt{3000} = 186 \text{ psi} = 0.186 \text{ ksi}$$

$$\therefore 0.186 \{4 \times (11.5 + d) d\} = 253.2 - 2.751 \times (11 + d) \times (12 + d)/(12)^2$$

$$\Rightarrow d^2 + 11.5 d = 339.9 - (11 + d) \times (12 + d)/38.99 \Rightarrow d = 12.48''$$

$\therefore$  Take footing thickness,  $t = 16.5'' \Rightarrow d = 12.5''$

$$\text{Flexural Shear strength} = 2\phi\sqrt{f_c'} = 2 \times 0.85\sqrt{3000} = 93.1 \text{ psi} = 13.41 \text{ ksf}$$

$$\text{Maximum shear force (according to SFD)} = 141.6^k$$

$$\therefore \text{Maximum flexural shear force} = 141.6 - 27.51d \quad [d \text{ is in ft}]$$

$$\therefore 13.41 \times 10 \times d = 141.6 - 27.51d \Rightarrow d = 0.876' = 10.52'' < 12.5'', \text{ OK.}$$

$$\text{Maximum bending moment (according to BMD)} = 288.6 \text{ k'}$$

$$\therefore \text{Depth required by M is} = \sqrt{(M/R_u b)} = \sqrt{\{288.6/(0.781 \times 10)\}} = 6.08'' < 12.5'', \text{ OK.}$$

$$\therefore A_s^{(-)} = (f_c/f_y)[1 - \sqrt{\{1 - 2M^{(-)}/(\phi f_c b d^2)\}}]bd = 8.03 \text{ in}^2$$

$$\text{and } A_s^{(+)} = (f_c/f_y)[1 - \sqrt{\{1 - 2M^{(+)}/(\phi f_c b d^2)\}}]bd = 3.47 \text{ in}^2 \text{ [using } M^{(+)} = 127.8 \text{ k'}]$$

$$A_{s(\min)} = (0.2/f_y)bd = (0.2/40) \times 10.00 \times 12 \times 12.5 = 7.50 \text{ in}^2, \text{ which is } < A_s^{(-)} \text{ but } > A_s^{(+)}$$

$\therefore$  Provide 13 #7 bars at top and bottom.

$$\text{Width of the transverse beams under columns} = 11 + 12.5 = 23.5''$$

$$\text{Load per unit length under } C_8 = 253.2/10 = 25.32 \text{ k'}$$

$$\therefore \text{Maximum bending moment} = 25.32 \times [(10 - 12/12)/2]^2/2 = 256.4 \text{ k'}$$

$$\therefore \text{Depth required by M is} = \sqrt{(M/R_u b)} = \sqrt{\{256.4 \times 12/(0.781 \times 23.5)\}} = 12.95'' > 11.5''.$$

$\therefore$  Provide  $d = 13.5''$ , increase the thickness to 17.5'' and put transverse rods at bottom

$$\therefore A_s^{(+)} = (f_c/f_y)[1 - \sqrt{\{1 - 2M^{(+)}/(\phi f_c b d^2)\}}]bd = 7.86 \text{ in}^2 \quad [\text{Note: } d = 13.5'' \text{ here}]$$

$$\text{Similarly, } A_s^{(+)} \text{ under } C_6 = 6.21 \text{ in}^2 \text{ and } A_s^{(+)} \text{ under } C_7 = 2.30 \text{ in}^2$$

$$\therefore A_{s(\min)} = (0.2/f_y)bd = (0.2/40) \times 23.5 \times 13.5 = 1.59 \text{ in}^2 < A_s^{(+)} \text{ for all columns}$$

$\therefore$  Provide 11#7, 4#7 and 13#7 bars at bottom within the width of the transverse beams (23.5'') under each column (in placing 13 #7 bars in 23.5'', be careful about minimum spacing).

Elsewhere, provide  $(0.2/f_y)bd = 0.81 \text{ in}^2/\text{ft}$  (i.e., #7 @ 9'' c/c).



Details of Individual Footing

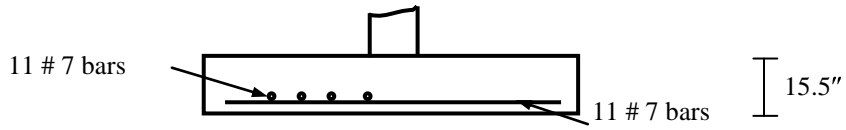
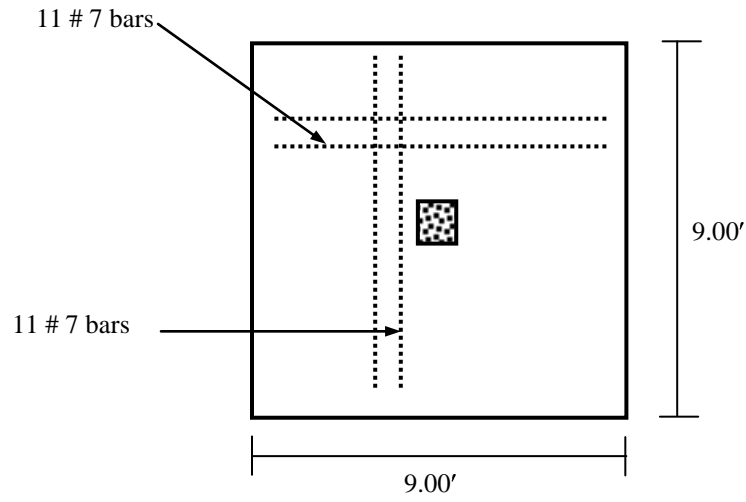

Details of Combined Footing

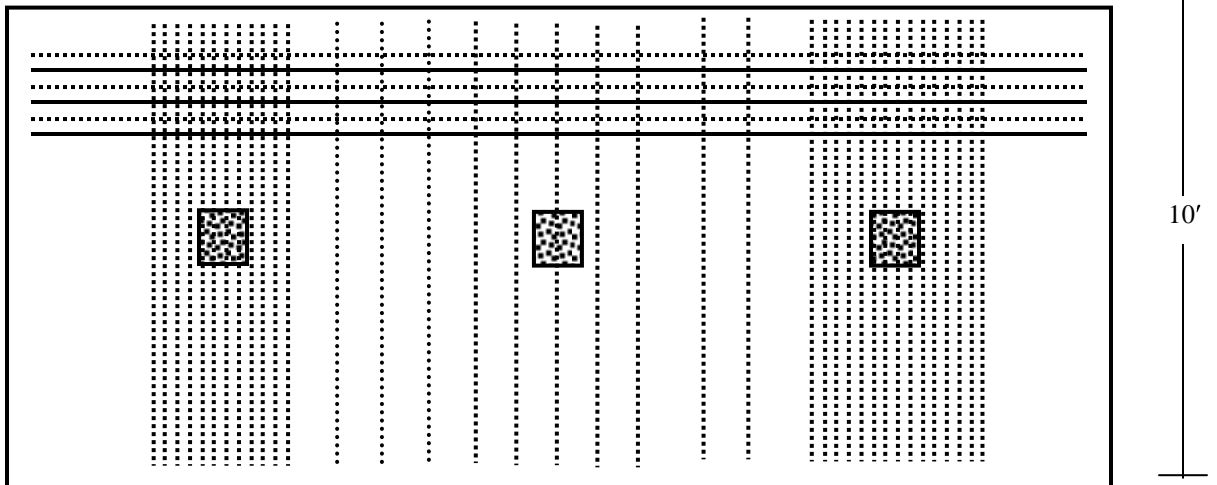
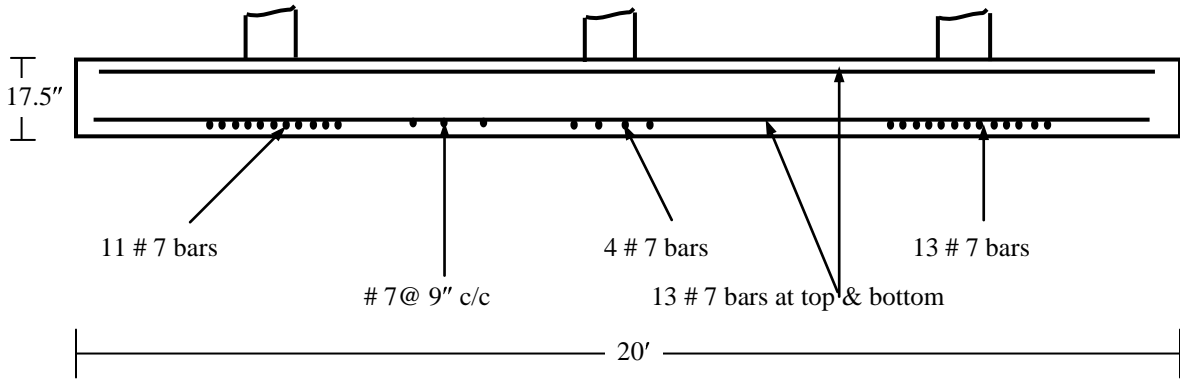

## Seismic Detailing of RC Structures

### 1. Materials

	Specification	Possible Explanation
Concrete	$f'_c \geq 20 \text{ Mpa}$ ( $\cong 3 \text{ ksi}$ ) for 3-storied or taller buildings	Weak concretes have low shear and bond strengths and cannot take full advantage of subsequent design provisions
Steel	$f_y \leq 415 \text{ Mpa}$ ( $\cong 60 \text{ ksi}$ ), preferably $\leq 250 \text{ Mpa}$ ( $\cong 36 \text{ ksi}$ )	Lower strength steels have (a) a long yield region, (b) greater ductility, (c) greater $f_{ult}/f_y$ ratio

### 2. Flexural Members (members whose factored axial stress $\leq f'_c/10$ )

	Specification	Possible Explanation
Size	$b/d \geq 0.3$	To ensure lateral stability and improve torsional resistance
	$b \geq 8''$	To (a) decrease geometric error, (b) facilitate rod placement
	$d \leq L_c/4$	Behavior and design of deeper members are significantly different
Longitudinal Reinforcement	$N_{s(\text{top})}$ and $N_{s(\text{bottom})} \geq 2$	Construction requirement
	$\rho \geq 0.1\sqrt{f'_c}/f_y$ ( $f'_c, f_y$ in ksi) at both top and bottom	To avoid brittle failure upon cracking
	$\rho \leq 0.025$ at top or bottom	To (a) cause steel yielding before concrete crushing and (b) avoid steel congestion
	$A_{s(\text{bottom})} \geq 0.5A_{s(\text{top})}$ at joint and $A_{s(\text{bottom})/(\text{top})} \geq 0.25A_{s(\text{top}) (\text{max})}$ at any section	To ensure (a) adequate ductility, (b) minimum reinforcement for moment reversal
	Both top and bottom bars at an external joint must be anchored $\geq L_d + 10d_b$ from inner face of column with $90^\circ$ bends	To ensure (a) adequate bar anchorage, (b) joint ductility
	Lap splices are allowed for $\leq 50\%$ of bars, only where stirrups are provided $@ \leq d/4$ or $4''$ c/c	Closely spaced stirrups are necessary within lap lengths because of the possibility of loss of concrete cover
	Lap splice lengths $\geq L_d$ and are not allowed within distance of $2d$ from joints or near possible plastic hinges	Lap splices are not reliable under cyclic loading into the inelastic range

## 2. Flexural Members (continued)

	Specification	Possible Explanation
Web Reinforcement	Web reinforcements must consist of closed vertical stirrups with 135° hooks and $10d_t (\geq 3'')$ extensions	To provide lateral support and ensure strength development of longitudinal bars
	Design shear force is the maximum of (a) shear force from analysis, (b) shear force due to vertical loads plus as required for flexural yielding of joints	It is desirable that the beams should yield in flexure before failure in shear
	Spacing of hoops within $2d$ (beginning at $\leq 2''$ ) at either end of a beam must be $\leq d/4, 8d_b$ ; elsewhere $S_t \leq d/2$	To (a) provide resistance to shear, (b) confine concrete to improve ductility, (c) prevent buckling of longitudinal compression bars

## 3. Axial Members (members whose factored axial stress $\geq f_c'/10$ )

	Specification	Possible Explanation
Size	$b_c/h_c \geq 0.4$	To ensure lateral stability and improve torsional resistance
	$b_c \geq 12''$	To avoid (a) slender columns, (b) column failure before beams
Longitudinal Reinforcement	Lap splices are allowed only for $\leq 50\%$ of bars, only where stirrups are provided @ $\leq b_c/4$ or $4''$	Closely spaced stirrups are necessary within lap lengths because of the possibility of loss of concrete cover
	Lap splice lengths $\geq L_d$ and only allowed in the center half of columns	Lap splices are not reliable under cyclic loading into the inelastic range
	$0.01 \leq \rho_g \leq 0.06$	To (a) ensure effectiveness and (b) avoid congestion of longitudinal bars
	$\sum M_{c,ult} \geq 1.2 \sum M_{b,ult}$ at joint	To obtain 'strong column weak beam condition' to avoid column failure before beams
Transverse Reinforcement	Transverse reinforcement must consist of closed spirals or rectangular/circular hoops with 135° hooks with $10d_t (\geq 3'')$ extensions	To provide lateral support and ensure strength development of longitudinal bars
	Parallel legs of rectangular hoops must be spaced @ $\leq 12''$ c/c	To provide lateral support and ensure strength development of longitudinal bars
	Spacing of hoops within $L_0 (\geq d_c, h_c/6, 18'')$ at each end of column must be $\leq b_c/4, 4''$ ; else $S_t \leq b_c/2$	To (a) provide resistance to shear, (b) confine concrete to improve ductility, (c) prevent buckling of longitudinal compression bars

### 3. Axial Members (continued)

	Specification	Possible Explanation
Transverse Reinforcement	Design shear force is the maximum of (a) shear force from analysis, (b) shear force required for flexural yielding of joints	It is desirable that the columns should yield in flexure before failure in shear
	Special confining reinforcement (i.e., $S_t \leq b_c/4, 4''$ ) should extend at least 12'' into any footing	To provide resistance to the very high axial loads and flexural demands at the base
	Special confining reinforcement (i.e., $S_t \leq b_c/4, 4''$ ) should be provided over the entire height of columns supporting discontinued stiff members and extend $L_d$ into the member	Discontinued stiff members (e.g., shear walls, masonry walls, bracings, mezzanine floors) may develop significant forces and considerable inelastic response
	For special confinement, area of circular spirals $\geq 0.11 S_t d (f_c'/f_y)(A_g/A_c-1)$ , of rectangular hoops $\geq 0.3 S_t d (f_c'/f_y)(A_g/A_c-1)$	To ensure load carrying capacity upto concrete spalling, taking into consideration the greater effectiveness of circular spirals compared to rectangular hoops. It also ensures toughness and ductility of columns

### 4. Joints of Frames

	Specification	Possible Explanation
Transverse Reinforcement	Special confining reinforcement (i.e., $S_t \leq b_c/4, 4''$ ) should extend through the joint	To provide resistance to the shear force transmitted by framing members and improve the bond between steel and concrete within the joint
	$S_t \leq b_c/2, 6''$ through joint with beams of width $b \geq 0.75b_c$	Some confinement is provided by the beams framing into the vertical faces of the joint

## Seismic Detailing of a Typical Frame

### Original Design of Frame (3)

Beams	SF <sub>1</sub> (D)	SF <sub>2</sub> (D)	BM <sub>1</sub> (D)	BM <sub>0</sub> (V=D)	BM <sub>2</sub> (D)
B <sub>16</sub>	9.3	-9.6	-23.0	12.4	-22.9
B <sub>20</sub>	6.5	-5.6	5.5, -17.6	0.7	8.2, -13.7

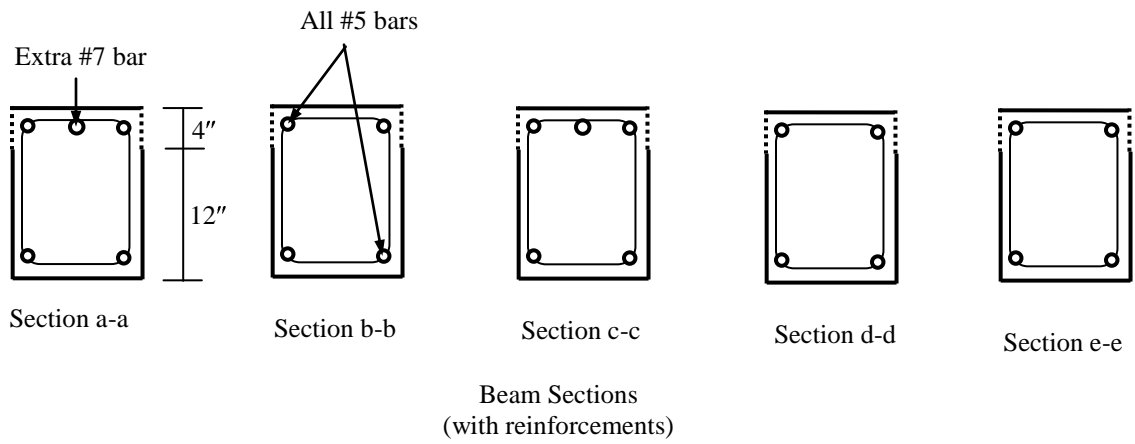
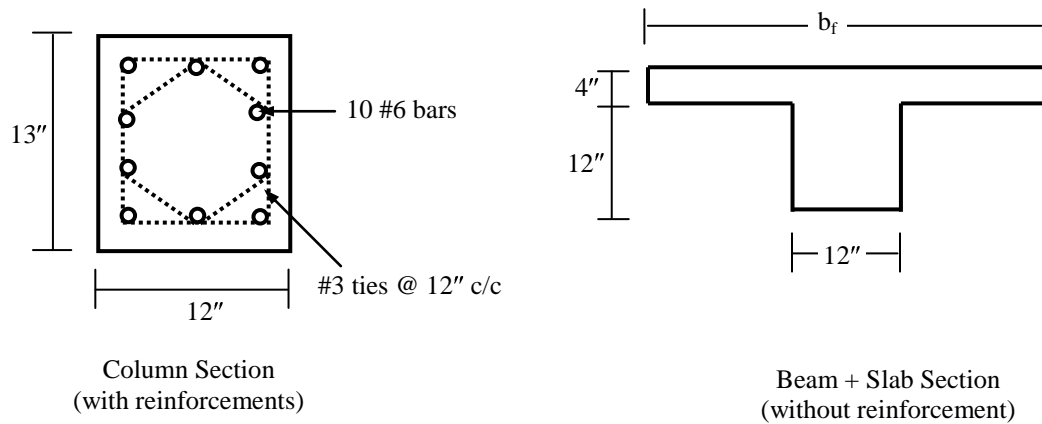

The reinforcements are arranged as follows

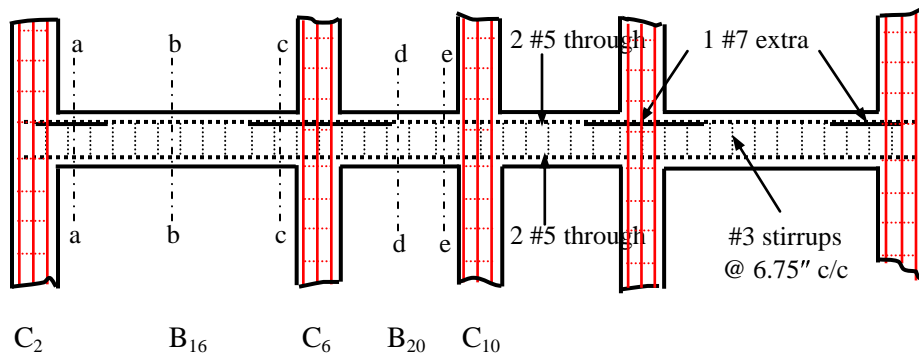

## 1. Materials

	Specification	Design Condition	Comments
Concrete	$f_c' \geq 20 \text{ Mpa}$ ( $\cong 3 \text{ ksi}$ ) for 3-storied or taller buildings	$f_c' = 3 \text{ ksi}$	OK
Steel	$f_y \leq 415 \text{ Mpa}$ ( $\cong 60 \text{ ksi}$ ), preferably $\leq 250 \text{ Mpa}$ ( $\cong 36 \text{ ksi}$ )	$f_y = 40 \text{ ksi}$	OK

## 2. Flexural Members (members whose factored axial stress $\leq f_c'/10$ )

	Specification	Design Condition	Comments
Size	$b/d \geq 0.3$	$b/d = 12/13.5 = 0.89$	OK
	$b \geq 8''$	$b = 12''$	OK
	$d \leq L_c/4$	$d = 13.5'', L_c/4 = 3' \text{ and } 1.5'$	OK
Longitudinal Reinforcement	$N_{s(\text{top})}$ and $N_{s(\text{bottom})} \geq 2$	$N_{s(\text{top})} \geq 2, N_{s(\text{bottom})} = 2$	OK
	$\rho \geq 0.1\sqrt{f_c'}/f_y$ (= 0.0043) at both top and bottom	$A_{s(\text{top})} = 0.62, 1.22 \text{ in}^2$ $A_{s(\text{bottom})} = 0.62 \text{ in}^2$ $\rho_{(\text{top})} = 0.0038, 0.0075$ $\rho_{(\text{bottom})} = 0.0038$	Both $\rho_{(\text{top})}$ and $\rho_{(\text{bottom})}$ are not OK
	$\rho \leq 0.025$ at top or bottom	Maximum $\rho = 0.0075$	OK
	$A_{s(\text{bottom})} \geq 0.5A_{s(\text{top})}$ at joint and $A_{s(\text{bottom})/(\text{top})} \geq 0.25A_{s(\text{top}) (\text{max})}$ at any section	$A_{s(\text{top})} = 0.62, 1.22 \text{ in}^2$ $A_{s(\text{bottom})} = 0.62 \text{ in}^2$ (through)	OK
	Both top and bottom bars at an external joint must be anchored $\geq L_d + 10d_b$ from inner face of column with $90^\circ$ bends	Not specified in design	Needs to be specified
	Lap splices are allowed for $\leq 50\%$ of bars, only where stirrups are provided $@ \leq d/4$ (= 3.38") or 4" c/c	Not specified in design	Needs to be specified
	Lap splice lengths $\geq L_d$ and are not allowed within distance of $2d$ (= 27") from joints or near possible plastic hinges	Not specified in design	Needs to be specified

## 2. Flexural Members (continued)

	Specification	Design Condition	Comments
Web Reinforcement	Web reinforcements must consist of closed vertical stirrups with 135° hooks, $10d_t \geq 3''$ extensions	Not specified in design	Needs to be specified
	Design shear force is the maximum of (a) shear force from analysis, (b) shear force due to vertical loads plus as required for flexural yielding of joints	Design shear force is taken only from analysis	Needs to be checked
	Spacing of hoops within $2d (= 27'')$ , beginning at $\leq 2''$ , at either end of a beam must be $\leq d/4$ , $8d_b (= 3.38'', 5'')$ elsewhere $S_t \leq d/2 (= 6.75'')$	$S_t = 6.75''$ c/c (= d/2) throughout the beams	Not OK

## 3. Axial Members (members whose factored axial stress $\geq f_c'/10$ )

	Specification	Design Condition	Comments
Size	$b_c/h_c \geq 0.4$	$b_c/h_c = 12/13 = 0.92$	OK
	$b_c \geq 12''$	$b_c = 12''$	OK
Longitudinal Reinforcement	Lap splices are allowed only for $\leq 50\%$ of bars, only where stirrups are provided @ $\leq b_c/4$ or $4''$	Not specified in design	Needs to be specified
	Lap splice lengths $\geq L_d$ and only allowed in the center half of columns	Not specified in design	Needs to be specified
	$0.01 \leq \rho_g \leq 0.06$	$A_s = 4.40 \text{ in}^2$ $\rho_g = 0.029$	OK
	$\sum M_{c,ult} \geq 1.2 \sum M_{b,ult}$ at joint	Not specified in design	Needs to be checked
Transverse Reinforcement	Stirrups must be closed rectangular/ circular hoops with 135° hooks with $10d_t (\geq 3.75'')$ extensions	Not specified in design	Needs to be specified
	Parallel legs of rectangular hoops must be spaced @ $\leq 12''$ c/c	Parallel legs of rectangular hoops spaced @ $\leq 10''$ c/c	OK
	Hoop spacing within $L_0 \geq d_c$ , $H_c/6$ , $18'' (= 10'', 18'', 18'')$ at each end of column $\leq b_c/4 (= 3''), 4''$ ; else $S_t \leq b_c/2 (= 6'')$	$S_t = 12''$ c/c throughout the columns	Not OK

### 3. Axial Members (continued)

	Specification	Design Condition	Comments
Transverse Reinforcement	Design shear force is the maximum of (a) shear force from analysis, (b) shear force required for flexural yielding of joints	Design shear force is taken only from analysis	Needs to be checked
	Special confining reinforcement (i.e., $S_t \leq 3''$ ) should extend at least 12" into any footing	Not specified in design	Needs to be specified
	Special confining reinforcement (i.e., $S_t \leq 3''$ ) should be provided over the entire height of columns supporting discontinued stiff members and extend $L_d$ into the member	Column supports no particular stiff member, but soft first storey	Special confining reinforcement (i.e., $S_t \leq 3''$ ) over the entire height of ground floor columns
	For special confinement, area of circular spirals $\geq 0.11 S_t d (f_c'/f_y)(A_g/A_c - 1)$ , of rectangular hoops $\geq 0.3 S_t d (f_c'/f_y)(A_g/A_c - 1)$ [ $= 0.3 \times 3 \times 9.5 (3/40) (156/90 - 1) = 0.47 \text{ in}^2$ ]	No special confinement provided and $0.22 \text{ in}^2$ hoop area provided @ 12" c/c	At least 2-legged #4 or 4-legged #3 bars needed as special confinement

### 4. Joints of Frames

	Specification	Design Condition	Comments
Transverse Reinforcement	Special confining reinforcement (i.e., $S_t \leq 3''$ ) should extend through the joint	Not specified in design	Needs to be specified
	$S_t \leq b_c/2 (= 6'')$ and 6" through joint with beams of width $b \geq 0.75b_c$	$b = 12''$ , $b_c = 12''$ , but no stirrups specified within joints	Since $b \geq 0.75b_c$ $\therefore S_t \leq 6''$ through joint



### Correct $A_{s(\min)}$ for Beams

The longitudinal steel ratio  $\rho$  is  $< \rho_{(\min)} = 0.1\sqrt{f_c'}/f_y (= 0.0043)$  in some cases

$\therefore$  If all the #5 bars are changed to #6 bars

$$A_{s(\text{top})} = 0.88, 1.48 \text{ in}^2, A_{s(\text{bottom})} = 0.88 \text{ in}^2$$

$$\rho_{(\text{top})} = 0.0054, 0.0091, \rho_{(\text{bottom})} = 0.0054, \text{ which are all } > \rho_{(\min)} \text{ and } < \rho_{(\max)} (= 0.025)$$

### Check Shear Capacity of Beams

Beams	SF (V)	SF (D)	SF (USD)
B <sub>16</sub>	9.6	9.6	14.4
B <sub>20</sub>	4.3	6.5	9.8

For Beam B<sub>16</sub>,  $a = A_s f_y / 0.85 f_c' b = 1.48 \times 40 / (0.85 \times 3 \times 12) = 1.93''$

$$M_{\text{ult}} \text{ at joint1} = A_s f_y (d - a/2) = 1.48 \times 40 \times (13.5 - 1.93/2) / 12 = 61.83 \text{ k'}$$

$$\text{Similarly, } A_s = 0.88 \text{ in}^2 \Rightarrow M_{\text{ult}} \text{ at joint2} = 37.91 \text{ k'}$$

$$V_{\text{Design}} = 1.4 (61.83 + 37.91) / 12 + 9.6 \times 1.5 = 26.04 \text{ k}$$

For Beam B<sub>20</sub>,  $V_{\text{Design}} = 1.4 (61.83 + 37.91) / 6 + 4.3 \times 1.5 = 29.72 \text{ k}$

$$V_c = 2\sqrt{f_c'} bd = 2\sqrt{(3/1000)} \times 12 \times 13.5 = 17.75 \text{ k}, V_{c1} = 6\sqrt{f_c'} bd = 53.24 \text{ k}$$

$$\therefore S_{\text{max}} = A_s f_y d / (V_n - V_c) = 0.22 \times 40 \times 13.5 / (29.72 / 0.85 - 17.75) = 6.89''$$

Stirrup spacing provided @6.75'' is just adequate, but special transverse reinforcements are spaced @3'' closer to the joints.

### Check Shear Capacity of Columns

Since the bending moments from analysis are small, shear forces are also assumed small; therefore the shear force is checked for flexural yielding of joints.

Also the column size is 13'' $\times$ 12''; i.e., the dimension 12'' works as h.

For Column C<sub>2</sub> at ground floor,  $P = 130.8 \times 1.4 = 183.12 \text{ k}$

$$P / (\phi A_g f_c') = 183.12 / (0.7 \times 13 \times 12 \times 3) = 0.56, \gamma = 7/12 \cong 0.6, \mu\rho = (40/2.55) \times 0.023 = 0.36$$

$$\therefore M / (\phi b_c h_c^2 f_c') = 0.18 \Rightarrow M = 0.18 (0.9 \times 13 \times 12^2 \times 3) = 909.79 \text{ k''} = 75.82 \text{ k'}$$

$$V_{\text{Design}} = 1.4 (75.82 + 75.82) / 9 = 23.59 \text{ k}$$

For Column C<sub>6</sub>,  $P = 140.2 \times 1.4 = 196.28 \text{ k}$

$$P / (\phi A_g f_c') = 196.28 / (0.7 \times 13 \times 12 \times 3) = 0.60, \text{ with } \gamma = 0.6, \mu\rho = 0.36$$

$$\therefore M / (\phi b_c h_c^2 f_c') = 0.17 \Rightarrow M = 0.17 (0.9 \times 13 \times 12^2 \times 3) = 859.25 \text{ k''} = 71.60 \text{ k'}$$

$$V_{\text{Design}} = 1.4 (71.60 + 71.60) / 9 = 22.28 \text{ k}$$

$$V_c = 2\sqrt{f_c'} bd = 2\sqrt{(3/1000)} \times 13 \times 9.5 = 13.53 \text{ k}, V_{c1} = 6\sqrt{f_c'} bd = 40.59 \text{ k}$$

$$\therefore S_{\text{max}} = A_s f_y d / (V_n - V_c) = 0.22 \times 40 \times 9.5 / (23.59 / 0.85 - 13.53) = 5.88''$$

Stirrup spacing provided @12'' throughout the columns is not adequate; i.e., provide #3 ties @5'' c/c, moreover special transverse reinforcements are spaced @3'' closer to the joints.

Check Moment Capacity of Joints (for Weak Beam Strong Column)

Since the first joint (between C<sub>2</sub> at two floors and B<sub>16</sub>) consists of one beam only with two columns, the second joint (between C<sub>6</sub> at two floors and B<sub>16</sub>, B<sub>20</sub>) is checked first for the Weak Beam Strong Column.

For ground floor Column C<sub>6</sub>,  $P = 140.2 \times 1.4 = 196.28 \text{ k}$

$$P/(\phi A_g f'_c) = 0.60, \text{ with } \gamma = 0.6, \mu\rho = 0.36 \Rightarrow M = 71.60 \text{ k'}$$

For first floor Column C<sub>6</sub>,  $P/(\phi A_g f'_c) \cong 3/4 \times 0.60 = 0.45$ , with  $\gamma = 0.6, \mu\rho = 0.36$

$$\therefore M/(\phi b_c h_c^2 f'_c) = 0.19 \Rightarrow M = 0.19 (0.9 \times 13 \times 12^2 \times 3) = 960.34 \text{ k''} = 80.03 \text{ k'}$$

$$\therefore \sum M_{c,ult} = 71.60 + 80.03 = 151.63 \text{ k'}, 1.2 \sum M_{b,ult} = 1.2 (37.91 + 37.91) = 90.98 \text{ k'}$$

$\therefore \sum M_{c,ult} > 1.2 \sum M_{b,ult}$ ; i.e., the Weak Beam Strong Column condition is satisfied.

The following sections are chosen as columns and beams

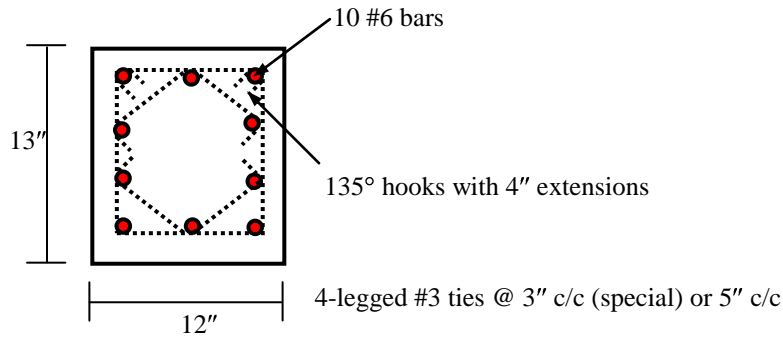

Column Section  
(with reinforcements)

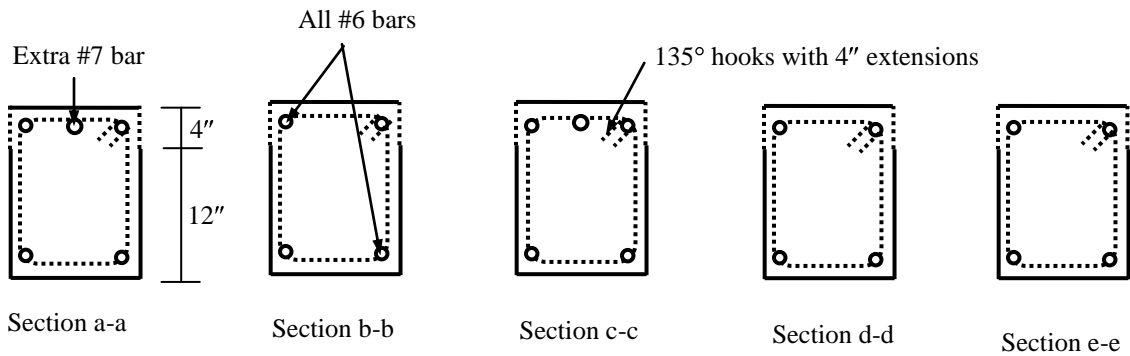

Beam Sections  
(with reinforcements)

The reinforcements are arranged as follows

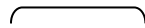
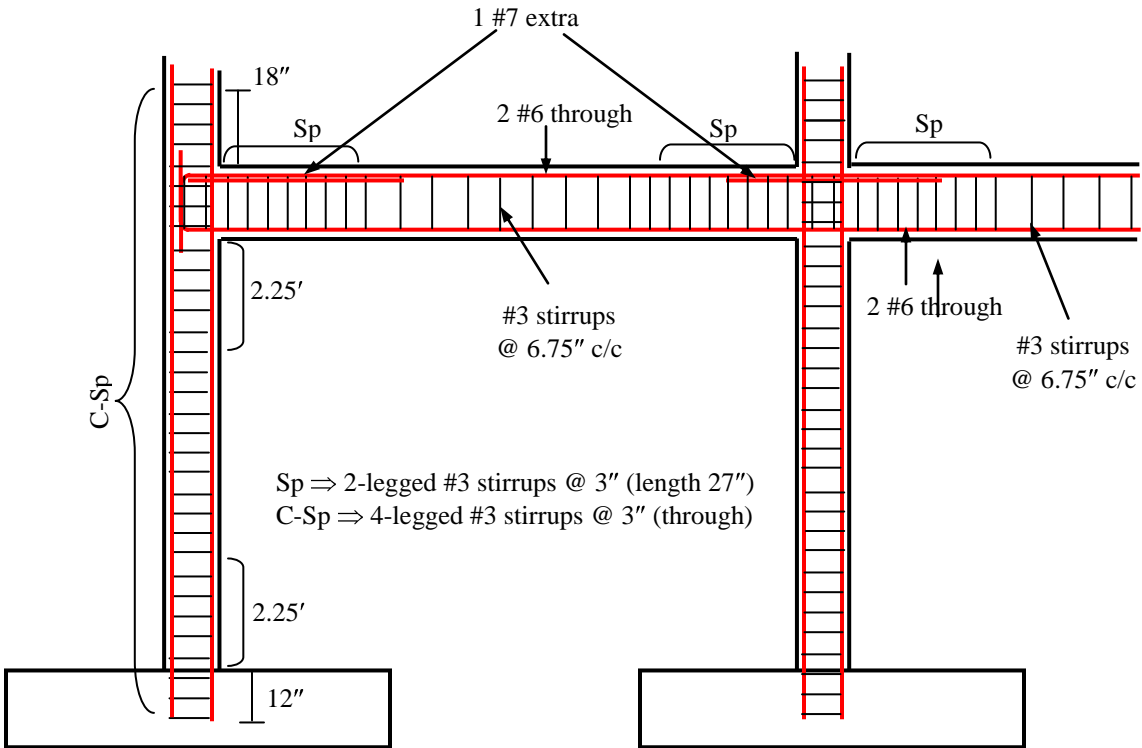

Lap-splices not allowed here

Elsewhere, it is only allowed for 50% bars with special confinement

Anchorage at end joints  $L_{anch} = L_d + 10 d_b$

$L_d$  for #7 bars  $= 0.04 A_s f_y / \sqrt{f'_c} = 0.04 \times 0.60 \times 40 / \sqrt{(3/1000)} \times 1.4 = 24.53''$

$L_{anch} = 24.53 + 10 \times 7/8 = 33.29''$ ; i.e., 34''

## Design of Shear Walls

### ACI Provisions for Shear Wall Design

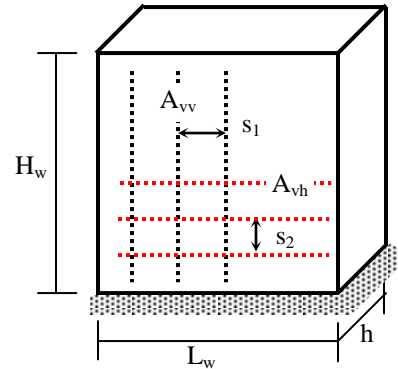

1. The thickness of the shear wall must be atleast 8 inch; i.e.,  $h \geq 8''$
2. Sections taken at  $L_w/2$  or  $H_w/2$  (whichever is less) from base is considered as critical for shear
3. In designing the horizontal shear forces or bending moments, the depth of the section is taken as  $d = 0.8L_w$
4. The nominal shear force, i.e., the permissible shear force in the section is
  - (i) greater the design shear force, i.e.,  $V_n = V_{\text{design}}/\phi$  [ $V = V_{\text{design}}$  in WSD]
  - (ii) summation of the shear force capacities of concrete and steel , i.e.,  $V_n = V_c + V_s$
  - (iii) cannot be greater than  $10\sqrt{f'_c} hd$ ; i.e.,  $V_n \leq 10\sqrt{f'_c} hd$  [ $V \leq 5\sqrt{f'_c} hd$  in WSD]
5. If  $N_u$  is taken as negative for tensile forces (lbs)
 

$V_c$  can be taken as  $\leq 2(1 + N_u/500A_g)\sqrt{f'_c} hd$  [ $V_c \leq 1.1(1 + N_u/500A_g)\sqrt{f'_c} hd$  in WSD]

Using a more detailed analysis,

$$V_c \leq 3.3\sqrt{f'_c} hd + N_u d / (4 L_w)$$

and  $\leq [0.6\sqrt{f'_c} + \{1.25\sqrt{f'_c} + 0.2 N_u / (h L_w)\} / \{M_u / (V_u L_w) - 0.5\}] hd$

[In WSD, take  $V_c$  to be about half of these]
6. If  $V_n \leq V_c/2$ , then the minimum horizontal reinforcements are provided
7. If  $V_n \geq V_c$ , then the horizontal reinforcements are spaced at
 
$$s_2 = A_{vh} f_y d / (V_n - V_c)$$
 [ $s_2 = A_{vh} f_s d / (V - V_c)$  in WSD] or ; where  $s_2 \leq L_w/5, 3h, 18''$   
 However,  $\rho_h = A_{vh} / (hs_2) \geq 0.0025$ ; i.e.,  $s_2 \leq A_{vh} / (0.0025 h)$
8. The vertical reinforcements are spaced at
 
$$s_1 \leq L_w/3, 3h, 18''$$

$$\rho_v = A_{vv} / (hs_1) = 0.0025 + 0.5 (2.5 - H_w/L_w) (\rho_h - 0.0025)$$
 However,  $\rho_v \geq 0.0025$  and  $\leq \rho_h$
9. Flexural reinforcements are provided like normal beams

### Shear Wall Design in the Long Direction of the Building

The long direction includes two Frame(1)'s and two Frame (2)'s.

Here, the height of the wall  $H_w = 40'$ , the length of the wall  $L_w = 7'$

Assuming only the rear wall to take all the loads (due to the large opening in the front wall), with similar seismic coefficients as taken initially for the frame analysis, the following lateral forces are calculated in the long direction of the building.

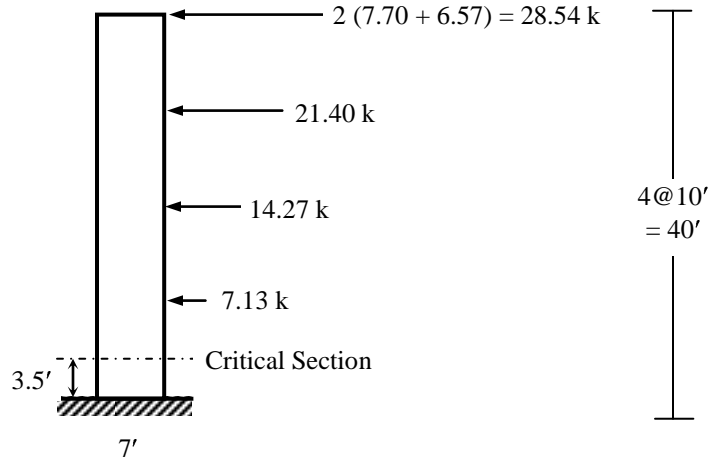

1. Assumed thickness of the wall,  $h = 8''$
2. Sections taken at  $L_w/2$  ( $= 3.5'$  which is  $< H_w/2 = 20'$ ) from base can be considered as critical  
 $\therefore$  The nominal shear force,  $V = 28.54 + 21.40 + 14.27 + 7.13 = 71.24$  k
3. The depth chosen for design is,  $d \cong 0.8L_w = 0.8 \times 7 \times 12 = 67.2''$
4.  $V = 71.24$  k, while  $5\sqrt{f'_c} hd = 5\sqrt{(3/1000)} \times 8 \times 67.2 = 147.23$  k  
 $\therefore V \leq 5\sqrt{f'_c} hd \Rightarrow$  OK
5. Since there is no net tensile force on the section,  $V_c$  can be taken as  $= 1.1\sqrt{f'_c} hd = 32.39$  k
6. Here  $V$  is not  $\leq V_c/2$ , then the minimum horizontal reinforcements are not sufficient
7. Using 2-legged #3 bars, the horizontal reinforcements are spaced at  
 $s_2 = 0.22 \times 20 \times 67.2 / (71.24 - 32.39) = 7.61''$   
 Using 2-legged #4 bars,  $s_2 = 13.84''$   
 Also  $s_2 \leq (L_w/5 =) 16.8''$ ,  $(3h =) 24''$ ,  $18''$ ,  $(A_{vh}/0.0025 h =) 20''$   
 $\Rightarrow$  Use 2-legged #4 bars @  $14''$  c/c  
 $\therefore \rho_h = A_{vh}/(hs_2) = 0.40/(8 \times 14) = 0.0036$
8. Using 2-legged #4 bars as vertical reinforcements  
 $\rho_v = A_{vv}/(hs_1) = 0.0025 + 0.5 (2.5 - H_w/L_w) (\rho_h - 0.0025)$   
 $\Rightarrow 0.40/(8s_1) = 0.0025 + 0.5 (2.5 - 40/7) (0.0036 - 0.0025) = 0.0008 \Rightarrow s_1 = 64.26''$   
 However,  $s_1 \leq (L_w/3 =) 28''$ ,  $(3h =) 24''$ ,  $18''$ ,  $(A_{vv}/0.0025 h =) 20''$   
 $\Rightarrow$  Use 2-legged #4 bars @  $18''$  c/c  
 $\therefore \rho_h = A_{vv}/(hs_a) = 0.40/(8 \times 18) = 0.0028$ , which is  $\geq 0.0025$  and  $\leq \rho_h$

9. Flexural reinforcements are provided like normal beams

$$M_{\max} = 7.13 \times 10 + 14.27 \times 20 + 21.40 \times 30 + 28.54 \times 40 = 2140 \text{ k-ft}$$

$$\therefore A_s = M / (f_s j d) = 2140 \times 12 / (20 \times 0.87 \times 67.2) = 21.97 \text{ in}^2,$$

$\therefore$  Use 18 #10 bars on each side, to be curtailed over the height

